

## PROLINE® XE ULTRA-LOW NOX POWER DIRECT VENT

The ProLine® XE Ultra-Low NOx power direct vent water heaters utilize an innovative burner system, a combination of radiant heat and excess air to comply with Utah, South Coast Air Quality Management District and other California Air Quality Management Districts with similar requirements of less than 10 ng/J for ultra-low NOx emissions. The 0.70 Energy Factor qualifies these models for ENERGY STAR®.

### POWER DIRECT VENT DESIGN

- Combined horizontal and vertical vent runs up to 180 equivalent feet with 4" diameter venting (ABS, PVC, CPVC and polypropylene)
- Two-pipe sealed combustion system uses outside air, eliminating problems caused by insufficient indoor ventilation
- Reduced NOx emissions comply with air quality management district regulations

### ENERGY STAR® QUALIFIED

- All models meet the ENERGY STAR® requirement and may also qualify for local utility and rebate programs
- "Environmentally-Friendly" foam insulation reduces the amount of heat loss and contributes to overall energy efficiency
- Built-in heat traps on the water inlet and outlet reduce the amount of heat lost through piping

### DYNACLEAN™ DIFFUSER DIP TUBE

- Helps reduce lime and sediment buildup and maximizes hot water output. Made from long-lasting PEX cross-linked polymer.

### HOT-SURFACE IGNITOR

- More robust and reliable than standing pilot, and reduces energy consumption.

### BLUE DIAMOND® GLASS COATING

- Provides superior corrosion resistance compared to the industry-standard glasslining

### USER-FRIENDLY

- State-of-the-art electronic gas control provides more precise temperature control
- LED control light displays operation status and diagnostics information

### ENHANCED-FLOW BRASS DRAIN VALVE

- Our residential water heaters have a solid brass, tamper resistant, enhancedflow, ball type, drain valve.
- Uses a standard female hose fitting that allows for fast and easy draining during maintenance
- Designed for easy operation, this valve includes an integral screwdriver slot that features a ¼ turn (open/close) radius, which not only permits full straightthrough water flow but also a quick and positive shut off.

### CSA CERTIFIED AND ASME RATED T&P RELIEF VALVE

### DESIGN-CERTIFIED BY CSA INTERNATIONAL

- Certified at 150 psi working pressure.
- Certified to ANSI Z21.10.1-CSA 4.1 or ANSI Z21.10.3-CSA 4.3 standards governing storage tank-type water heaters

### AVAILABLE IN NATURAL GAS

### 6-YEAR LIMITED TANK AND PARTS WARRANTY





# COMMERCIAL-GRADE RESIDENTIAL GAS WATER HEATERS

Model Number	Nominal Capacity	Rated Storage Volume	First Hour Rating (Gallons)	UEF	BTU Input Per Hour	Recovery @ 90°F Rise Gallon Per Hour	Dimensions in Inches						Approx. Shipping Weight (lb)
							A	B	C	D	E	F	
UPDVG62-40S40	40	38	75	0.70	40,000	41	58-1/4	49-5/8	22	29-7/8	11	13-1/4	174
UPDVG62-50T40	50	48	75	0.70	40,000	43	67-1/2	58-3/4	22	29-7/8	11	13-1/4	192

Dimensions and specifications subject to change without notice in accordance with our policy of continuous product improvement.

All Dimensions shown in inches.

Top inlet and outlet are on 8" centers.

Operates on Natural Gas only.

All models rated for installation at altitudes up to 5,400 ft. Use high altitude kit for elevations to 10,100 ft.

For installations where the Ambient temperature is between 110 F° and 140 F° the High Ambient kit is required.

Vent Length			
Model Number	Maximum Vent Length Eq. Ft.		
	Ø2"	Ø3"	Ø4"
UPDVG62-40S40	50'	125'	180'
UPDVG62-50T40	50'	125'	180'

Optional Kits	
Description	Part Number
2" Concentric Vent Kit	100112869
3" Low Profile Concentric Vent Kit	100187887
High Ambient Kit	100191116
High Altitude Kit	100308933

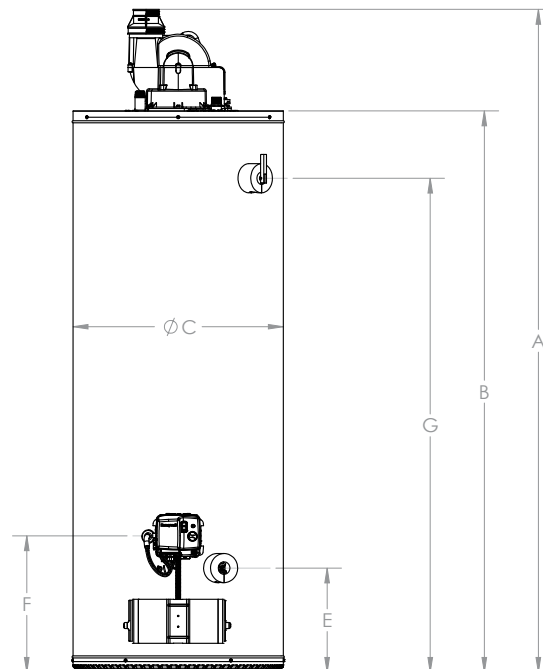
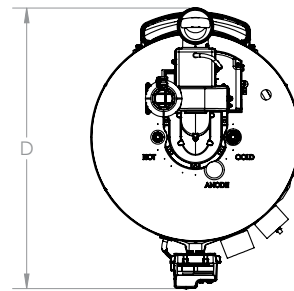

For technical information call (800) 999-9515. American Water Heaters reserves the right to make product changes or improvements without prior notice.