



---

# Direct Vent Residential Gas Water Heater Installation Instructions and Use & Care Guide

## Ultra Low NOx MODELS

**WARNING:** If the information in these instructions is not followed exactly, a fire or explosion may result causing property damage, personal injury or death.

Do not store or use gasoline or other flammable vapors and liquids in the vicinity of this or any other appliance.

### WHAT TO DO IF YOU SMELL GAS

- Do not try to light any appliance.
- Do not touch any electrical switch; do not use any phone in your building.
- Immediately call your gas supplier from a neighbor's phone. Follow the gas supplier's instructions.
- If you cannot reach your gas supplier, call the fire department.

Installation and service must be performed by a qualified installer, service agency or the gas supplier.

To obtain technical, warranty, or service assistance during or after the installation of this water heater, visit our website at:

<http://www.americanwaterheater.com>

or call toll free  
1-800-999-9515

When calling for assistance, please have the following information ready:

1. Model number
2. 7 digit product number
3. Serial number
4. Date of installation
5. Place of purchase

---

Table of Contents .....	2
-------------------------	---

---

### INSTALLER:

- AFFIX THESE INSTRUCTIONS TO OR ADJACENT TO THE WATER HEATER.

### OWNER:

- RETAIN THESE INSTRUCTIONS AND WARRANTY FOR FUTURE REFERENCE. RETAIN THE ORIGINAL RECEIPT AS PROOF OF PURCHASE.



LOW LEAD  
CONTENT

325002-000  
January 2013

# WATER HEATER SAFETY

## Your safety and the safety of others are very important.

We have provided many important safety messages in this manual and on your appliance. Always read and obey all safety messages.



This is the safety alert symbol.

This symbol alerts you to potential hazards that can kill or hurt you and others.

All safety messages will follow the safety alert symbol and either the word "DANGER" or "WARNING." These words mean:

**⚠ DANGER**

Indicates an imminently hazardous situation which, if not avoided, will result in death or injury.

**⚠ WARNING**

Indicates a hazardous situation which, if not avoided, could result in death or serious injury.

All safety messages will tell you what the potential hazard is, tell you how to reduce the chance of injury, and tell you what can happen if the instructions are not followed.

### Important Instructions

- Do not use this appliance if any part has been under water. Immediately call a qualified person. Water heaters subjected to flood conditions or any time the gas controls, main burner or pilot have been submerged in water require replacement of the entire water heater.
- Hydrogen gas can be produced in a hot water system that has not been used for a long period of time (generally two weeks or more). Hydrogen gas is extremely flammable and can ignite when exposed to a spark or flame. To prevent the possibility of injury under these conditions, we recommend the hot water faucet be opened for several minutes at the kitchen sink before using any electrical appliance which is connected to the hot water system. If hydrogen is present, there will probably be an unusual sound such as air escaping through the faucet as water begins to flow. Do not smoke or have any open flame near the faucet at the time it is open.

The California Safe Drinking Water and Toxic Enforcement Act requires the Governor of California to publish a list of substances known to the State of California to cause cancer, birth defects, or other reproductive harm, and requires businesses to warn of potential exposure to such substances.

**WARNING:** This product contains a chemical known to the State of California to cause cancer, birth defects, or other reproductive harm.

This product is certified to comply with a maximum weighted average of 0.25% lead content as required in some areas.

## Table Of Contents

	PAGE
Water Heater Safety .....	1-3
Installing Your Gas Water Heater .....	4-16
Unpacking the Water Heater.....	4
Location Requirements.....	5-6
Gas Supply .....	7-8
Combustion Air Supply and Ventilation.....	8-12
Water System Piping .....	13-14
Temperature & Pressure Relief Valve.....	15
Special Applications.....	16
Installation Checklist.....	17
Operating Your Water Heater .....	18-22
Lighting Instructions.....	18
Operating the Temperature Control System .....	21
Operational Conditions .....	22
Maintenance of Your Water Heater .....	23-27
Troubleshooting Charts .....	27-29
Repair Parts Illustration .....	30-31

## INSTALLATION REQUIREMENTS FOR THE COMMONWEALTH OF MASSACHUSETTS

For all side wall terminated, horizontally vented power vent, direct vent, and power direct vent gas fueled water heaters installed in every dwelling, building or structure used in whole or in part for residential purposes, including those owned or operated by the Commonwealth and where the side wall exhaust vent termination is less than seven (7) feet above finished grade in the area of the venting, including but not limited to decks and porches, the following requirements shall be satisfied:

**INSTALLATION OF CARBON MONOXIDE DETECTORS** At the time of installation of the side wall horizontal vented gas fueled equipment, the installing plumber or gasfitter shall observe that a hard wired carbon monoxide detector with an alarm and battery back-up is installed on the floor level where the gas equipment is to be installed. In addition, the installing plumber or gasfitter shall observe that a battery operated or hard wired carbon monoxide detector with an alarm is installed on each additional level of the dwelling, building or structure served by the sidewall horizontal vented gas fueled equipment. It shall be the responsibility of the property owner to secure the services of qualified licensed professionals for the installation of hard wired carbon monoxide detectors.

In the event that the side wall horizontally vented gas fueled equipment is installed in a crawl space or an attic, the hard wired carbon monoxide detector with alarm and battery back-up may be installed on the next adjacent floor level.

In the event that the requirements of this subdivision can not be met at the time of completion of installation, the owner shall have a period of thirty (30) days to comply with the above requirements provided that during said thirty (30) day period, a battery operated carbon monoxide detector with an alarm shall be installed.

**APPROVED CARBON MONOXIDE DETECTORS** Each carbon monoxide detector as required in accordance with the above provisions shall comply with NFPA 720 and be ANSI/UL 2034 listed and CSA certified.

**SIGNAGE** A metal or plastic identification plate shall be permanently mounted to the exterior of the building at a minimum height of eight (8) feet above grade directly in line with the exhaust vent terminal for the horizontally vented gas fueled heating appliance or equipment. The sign shall read, in print size no less than one-half (1/2) inch in size, "**GAS VENT DIRECTLY BELOW. KEEP CLEAR OF ALL OBSTRUCTIONS.**"

**INSPECTION** The state or local gas inspector of the side wall horizontally vented gas fueled equipment shall not approve the installation unless, upon inspection, the inspector observes carbon monoxide detectors and signage installed in accordance with the provisions of 248 CMR 5.08(2)(a) 1 through 4.

**EXEMPTIONS:** The following equipment is exempt from 248 CMR 5.08(2)(a)1 through 4:

1. The equipment listed in Chapter 10 entitled "Equipment Not Required To Be Vented" in the most current edition of NFPA 54 as adopted by the Board; and
2. Product Approved side wall horizontally vented gas fueled equipment installed in a room or structure separate from the dwelling, building, or structure used in whole or in part for residential purposes.

**MANUFACTURER REQUIREMENTS - GAS EQUIPMENT VENTING SYSTEM PROVIDED** When the manufacturer of Product Approved side wall horizontally vented gas equipment provides a venting system design or venting system components with the equipment, the instructions provided by the manufacturer for installation of the equipment and the venting system shall include:

1. Detailed instructions for the installation of the venting system design or the venting system components; and
2. A complete parts list for the venting system design or venting system.

**MANUFACTURER REQUIREMENTS - GAS EQUIPMENT VENTING SYSTEM NOT PROVIDED** When the manufacturer of a Product Approved side wall horizontally vented gas fueled equipment does not provide the parts for venting the flue gases, but identifies "special venting systems," the following requirements shall be satisfied by the manufacturer:

1. The referenced "special venting system" instructions shall be included with the appliance or equipment installation instructions; and
2. The "special venting systems" shall be Product Approved by the Board, and the instructions for that system shall include a parts list and detailed installation instructions.

A copy of all installation instructions for all Product Approved side wall horizontally vented gas fueled equipment, all venting instructions, all parts lists for venting instructions, and/or all venting design instructions shall remain with the appliance or equipment at the completion of the installation.

# INSTALLING YOUR GAS WATER HEATER

## Important Information About This Water Heater

This gas water heater was manufactured to voluntary safety standards to reduce the likelihood of a flammable vapor ignition incident. New technology used in meeting these standards makes this product more sensitive to installation errors or improper installation environments. Please review the Installation Checklist found at the end of the installation instructions section and make any required installation upgrades or changes.

## Consumer Information

This water heater is design-certified by CSA International as a Category I, direct vented water heater which takes its combustion air from the outside of the structure and exhausts all products of combustion to the outside of the structure.

This water heater must be installed according to all local and state codes or, in the absence of local and state codes, the "National Fuel Gas Code", ANSI Z223.1(NFPA 54)-current edition. This is available from the following:

CSA America, Inc.  
8501 East Pleasant Valley Road  
Cleveland, OH 44131

National Fire Protection Association  
1 Batterymarch Park  
Quincy, MA 02269

Check your phone listings for the local authorities having jurisdiction over your installation.

## Consumer Responsibilities

This manual has been prepared to acquaint you with the installation, operation, and maintenance of your gas water heater and provide important safety information in these areas.

Read all of the instructions thoroughly before attempting the installation or operation of this water heater.

Do not discard this manual. You or future users of this water heater will need it for future reference.

**IMPORTANT:** The manufacturer and seller of this water heater will not be liable for any damages, injuries, or deaths caused by failure to comply with the installation and operating instructions outlined in this manual.

If you lack the necessary skills required to properly install this water heater, or you have difficulty following the instructions, you should not proceed but have a qualified person perform the installation of this water heater. Massachusetts code requires this water heater to be installed in accordance with Massachusetts Plumbing and Fuel Gas Code 248 CMR Section 2.00 and 5.00.

A data plate identifying your water heater can be found next to the gas control valve/thermostat. When referring to your water heater, always have the information listed on the data plate readily available.

Retain your original receipt as proof of purchase.

## Unpacking the Water Heater

### **WARNING**

#### **Excessive Weight Hazard**

**Use two or more people to move and install water heater.**

**Failure to do so can result in back or other injury.**

**IMPORTANT:** Do not remove any permanent instructions, labels, or the data label from either the outside of the water heater or on the inside of water heater panels.

- Remove exterior packaging and place installation components aside.
- Inspect all parts for damage prior to installation and start-up.
- Completely read all instructions before attempting to assemble and install this product.
- After installation, dispose of/recycle all packaging materials.

**⚠ WARNING**



**FIRE AND EXPLOSION HAZARD**  
Can result in serious injury or death

**⚠ Do not store or use gasoline or other flammable vapors and liquids in the vicinity of this or any other appliance. Storage of or use of gasoline or other flammable vapors or liquids in the vicinity of this or any other appliance can result in serious injury or death.**

**Read and follow water heater warnings and instructions.**

## Site Location

- Select a location near the center of the water piping system. The water heater must be installed indoors and in a vertical position on a level surface. **DO NOT** install in bathrooms, bedrooms, or any occupied room normally kept closed. Note: The water heater may be installed in a closet with a door off a bedroom or bathroom providing the units are installed and vented per the manufacturer's instructions..
- Consider the vent piping and vent cap termination location. This is a direct vent water heater and may be vented through-the-wall. See the "Vent Cap Termination" section of this manual for the proper vent cap locations.
- Locate the water heater near the existing gas piping. If installing a new gas line, locate the water heater to minimize the pipe length and elbows.

**NOTE:** This water heater must be installed according to all local and state codes or, in the absence of local and state codes, the "National Fuel Gas Code", ANSI Z223.1(NFPA 54)-current edition.

## Location Requirements

**⚠ WARNING**

**Carbon Monoxide Poisoning Hazard**

**Do not install in a mobile home.**

**Doing so can result in death or carbon monoxide poisoning.**

This water heater design has been tested by CSA International and complies with ANSI Z21.10.1, Section 2.35 Flammable Vapors Resistance. Therefore this water heater does not need to be installed 18 inches above the floor unless specifically required by state or local codes. The water heater must be located or protected to avoid physical damage by vehicles or flooding.

Do not use or store flammable products such as gasoline, solvents, or adhesives in the same room or area near the water heater. If such flammables must be used, all gas burning appliances in the vicinity must be shut off and their pilot lights extinguished. Open the doors and windows for ventilation while flammable substances are in use.

If flammable liquids or vapors have spilled or leaked in the area of the water heater, leave the area immediately and call the fire department from a neighbor's home. Do not attempt to clean the spill until all ignition sources have been extinguished.

Keep combustibles such as boxes, magazines, clothes, etc. away from the water heater area.

**IMPORTANT:** The water heater should be located in an area where leakage of the tank or connections will not result in damage to the area adjacent to the water heater or to lower floors of the structure. Due to the normal corrosive action of the water, the tank will eventually leak after an extended period of time. Also any external plumbing leak, including those from improper installation, may cause early failure of the tank due to corrosion if not repaired. If the homeowner is uncomfortable with making the repair a qualified person should be contacted. A suitable metal drain pan should be installed under the water heater as shown below, to help protect the property from damage which may occur from condensate formation or leaks in the piping connections or tank. The pan must limit the water level to a maximum depth of 1-3/4" and be two inches wider than the heater and piped to an adequate drain.

**NOTE:** The pan must not restrict combustion air flow. Locate the water heater near a adequate indoor drain. The discharge pipe must terminate a maximum of six inches above a floor drain or external to the building. In cold climates, it is recommended that the discharge pipe be terminated at an adequate drain inside the building. Outside drains are subject to freezing temperatures which can obstruct the drain line. The piping should be at least 3/4" ID and pitched for proper drainage. Under no circumstances will the manufacturer or seller of this water heater be held liable for any water damage which is caused by your failure to follow these instructions.

Figure 1  
Drain Pan Installation

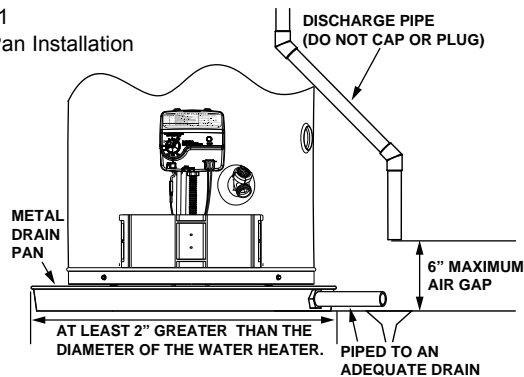

- The water heater should be located in an area not subject to freezing temperatures. Water heaters located in unconditioned spaces (i.e., attics, basements, etc.) may require insulation of the water piping and drain piping to protect against freezing. The drain and controls must be easily accessible for operation and service. Maintain proper clearances as specified on the data plate.

## Clearances and Accessibility

**NOTE:** Minimum clearances from combustible surfaces are stated on the data plate adjacent to the gas control valve/ thermostat of the water heater.

The water heater is certified for installation on a combustible floor.

- IMPORTANT:** If installing over carpeting, the carpeting must be protected by a metal or wood panel beneath the water heater. The protective panel must extend beyond the full width and depth of the water heater by at least three inches (76.2mm) in any direction; or if in

an alcove or closet installation, the entire floor must be covered by the panel.

- Figure 2 may be used as a reference guide to locate the specific clearance locations. A minimum of 24 inches of front clearance should be provided for inspection and service.

Figure 2

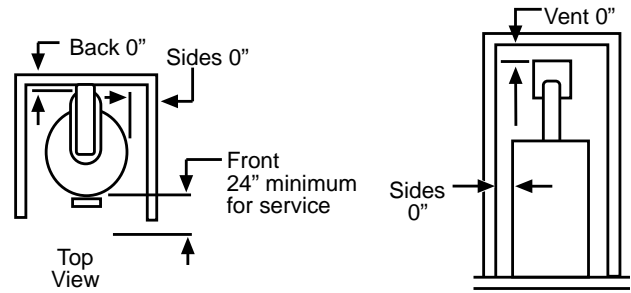

## State of California

**NOTE:** The water heater must be braced, anchored, or strapped to avoid moving during an earthquake. Correct installation procedure instructions may be obtained from California's Office of the State Architect, 1102 Q street, Suite 5100, Sacramento, CA 95811. Instructions can be downloaded to your computer at [www.dsa.dgs.ca.gov/Pubs](http://www.dsa.dgs.ca.gov/Pubs).

# Gas Supply

## ⚠ WARNING



### Explosion Hazard

Use a new CSA approved gas supply line.

Install a shut-off valve.

Do not connect a natural gas water heater to an L.P. gas supply.

Do not connect an L.P. gas water heater to a natural gas supply.

Failure to follow these instructions can result in death, explosion, or carbon monoxide poisoning.

## Gas Requirements

**IMPORTANT:** Read the data plate to be sure the water heater is made for the type of gas you will be using in your home. This information will be found on the data plate located near the gas control valve/thermostat. If the information does not agree with the type of gas available, do not install or light. Call your dealer.

**NOTE:** An odorant is added by the gas supplier to the gas used by this water heater. This odorant may fade over an extended period of time. Do not depend upon this odorant as an indication of leaking gas.

## Gas Piping

The gas piping must be installed according to all local and state codes or, in the absence of local and state codes, the "National Fuel Gas Code", ANSI Z223.1(NFPA 54)-current edition.

Tables 1 on page 8 provides a sizing reference for commonly used gas pipe materials. Consult the "National Fuel Gas Code" for the recommended gas pipe size of other materials.

Refer to Figure 3

**NOTE:** When installing gas piping, apply approved pipe joint compound.

1. Install a readily accessible manual shut-off valve in the gas supply line as recommended by the local utility. Know the location of this valve and how to turn off the gas to this unit.
2. Install a drip leg (if not already incorporated as part of the water heater) as shown. The drip leg must be no less than three inches long for the accumulation of dirt, foreign material, and water droplets.
3. Install a ground joint union between the gas control valve/thermostat and the manual shut-off valve. This is to allow easy removal of the gas control valve/thermostat.
4. Turn the gas supply on and check for leaks. Test all connections by brushing on an approved noncorrosive leak-detection solution. Bubbles will show a leak. Correct any leak found.

Figure 3  
Gas Piping

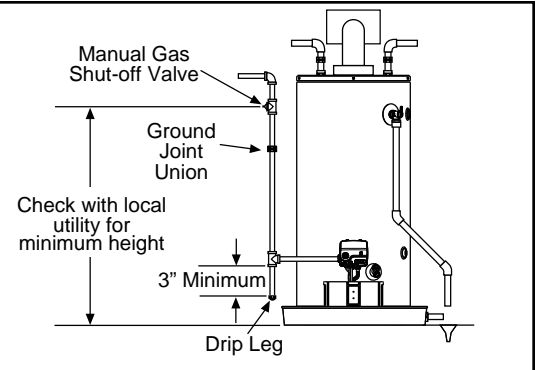

## Gas Pressure

**IMPORTANT:** The gas supply pressure must not exceed the maximum supply pressure as stated on the water heater's data plate. The minimum supply pressure is for the purpose of input adjustment.

## Gas Pressure Testing

**IMPORTANT:** This water heater and its gas connection must be leak tested before placing the appliance in operation.

- If the code requires the gas lines to be tested at a pressure exceeding 14" W.C., the water heater and its manual shut-off valve must be disconnected from the gas supply piping system and the line capped.
- If the gas lines are to be tested at a pressure less than 14" W.C., the water heater must be isolated from the gas supply piping system by closing its manual shut-off valve

U.L. recognized fuel gas and carbon monoxide (CO) detectors are recommended in all applications and should be installed using the manufacturer's instructions and local codes, rules, or regulations.

**NOTE:** Air may be present in the gas lines and could prevent the pilot from lighting on initial start-up. The gas lines should be purged of air by a qualified person after installation of the gas piping system. While purging the gas piping system of air, make sure that the fuel is not spilled in the area of the water heater installation, or any source of ignition. If the fuel is spilled while purging the piping system of air follow the "WHAT TO DO IF YOU SMELL GAS" instructions on the cover of this manual.

Table 1 Natural Gas Pipe Capacity Table (Cu. Ft./Hr.) Capacity of gas pipe of different diameters and lengths in cu. ft. per hr. with pressure drop of 0.3 in. and specific gravity of 0.60 (natural gas).														
Nominal Iron Pipe Size, in.	Length of Pipe, Feet													
	10	20	30	40	50	60	70	80	90	100	125	150	175	200
1/2	132	92	73	63	56	50	46	43	40	38	34	31	28	26
3/4	278	190	152	130	115	105	96	90	84	79	72	64	59	55
1	520	350	285	245	215	195	180	170	160	150	130	120	110	100
1-1/4	1050	730	590	500	440	400	370	350	320	305	275	250	225	210
1-1/2	1600	1100	890	760	670	610	560	530	490	460	410	380	350	320

After the length of pipe has been determined, select the pipe size which will provide the minimum cubic feet per hour required for the gas input rating of the water heater. By formula:

$$\text{Cu. Ft. Per Hr. Required} = \frac{\text{Gas Input of Water Heater (BTU/HR)}}{\text{Heating Value of Gas (BTU/FT}^3\text{)}}$$

The gas input of the water heater is marked on the water heater data plate. The heating value of the gas (BTU/FT<sup>3</sup>) may be determined by consulting the local natural gas utility.

Additional tables are available in the latest edition of the "National Fuel Gas Code", ANSI Z223.1.

## Combustion Air Supply and Ventilation

### **⚠️ WARNING**

#### **Carbon Monoxide Hazard**

**Water heater must be vented to outdoors.**

**Vent must be installed by a qualified person using the installation instructions.**

**Examples of a qualified person include: gas technicians, authorized gas company personnel, and authorized service persons.**

**Failure to follow these instructions can result in death or carbon monoxide poisoning.**

**IMPORTANT:** Air for combustion and ventilation must not come from a corrosive atmosphere. Any failure due to corrosive elements in the atmosphere is excluded from warranty coverage.

**IMPORTANT:** Do not common vent this water heater with any power vented appliance.

### **Vent Pipe System**

This is a direct vent water heater which draws its combustion air from outside of the structure and exhausts all products of combustion to the outside of the structure.

Through-the-wall installations require locating the water heater next to an outside wall. All necessary components are supplied for the standard through-the-wall installation. Optional vertical and horizontal extension kits are available for installations that exceed the standard horizontal and vertical distances (see table at right). Only one vertical and one horizontal kit can be used on the same installation.

### **Through the Wall Flex Pipe Venting**

1. Make sure a proper location has been selected for the water heater installation. Consider the following:
  - Water piping
  - Gas Piping
  - Access for service
  - Proper clearance for combustibles
  - Drainage for the temperature and pressure relief valve and drain pan.
  - Vent cap termination
2. Determine the "A" dimension for your specific water heater by referencing figure 4A. Cut a 6 inch opening through the wall in the location as shown. Determine the location of electrical wiring, pipes, or wall studs before cutting.

**NOTE:** Installations requiring an "A" dimension (vertical height) greater than what is shown will require the use of a Optional vertical extension kit (See "Vertical Install Kit" on Page 11).



3. Uncompressing the corrugated Flex piping by pulling the piping to the length as required. Make sure there are two springs evenly spaced at the bend in the pipe.
4. Determine the "A" and "B" dimensions for the size of the water heater being installed (Figure 4A). Dim. "A" is measured from the center of cutout to the bottom of heater. Maximum height for all water heaters is **90"**. Minimum height for 40 Gallon water heaters **68"** and minimum height for 50 Gallon water heaters is **76"** (Figure 4A). Dim. "B" is measured from the center of water heater to the outside of the exterior wall. Minimum horizontal is **22"** for all water heaters at the maximum height of **90"** (Figure 4A).
5. Cut a 6" opening through the wall in the location as shown. Note: location is determine first by locating all electrical wiring, pipes, and wall studs before cutting.
6. Metal hangers may be used to keep the pipe level or with a slope upward from the water heater through the wall to Vent Cap.
7. **At the water heater:** Pull the inner 3" corrugated pipe to the water heater's flue reducer and attached using the Small Clamp included in kit. Apply hi-temp silicone sealant around the connection making sure joint is tight and leak proof (Figure 4A).
8. Pull the outer corrugated Flex Vent pipe down covering the connection and secure using the Large Clamp included in kit to the collar at the Upper Air Box (Figure 4A). Apply hi-temp silicone sealant around the connection making sure joint is tight and leak proof.
9. **At the exterior wall:** Pull the Flex Vent piping through the Inner Wall Plate through the clearance hole from the exterior wall to the Outer Wall Plate. Secure Inner Wall Plate to the inside wall with 1/2" screws.
10. Pull the outer corrugated Flex Vent pipe out to the Outer Wall Plate, secure with Large Clamp. Pull the inner 3" corrugated pipe out from the Flex Vent pipe through the Outer Wall Plate and attached to the end of the 3" tube at the Vent Cap and secure using the Small Clamp included in kit. Apply hi-temp silicone sealant around the connection making sure the joint is tight and leak proof (Figure 4A).
11. Secure Vent Cap Assembly to the Outer Wall Plate to the exterior wall with four 1-1/2" screws provided in kit (Figure 4A). Note: varying wall structures may require a different type of screw anchor.
12. Apply hi-temp silicone sealant around the connection making sure the joint is tight and leak proof (Figure 4A).

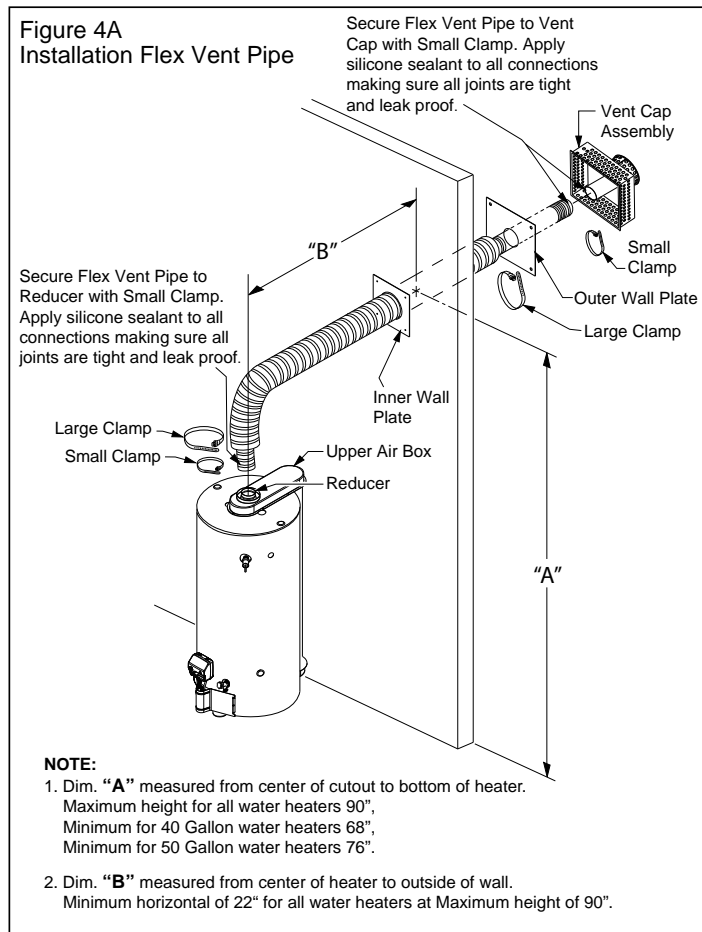

## Optional through the Wall Venting

1. Make sure a proper location has been selected for the water heater installation. Consider the following:
  - Water piping
  - Gas Piping
  - Access for service
  - Proper clearance for combustibles
  - Drainage for the temperature and pressure relief valve and drain pan.
  - Vent cap termination
2. Determine the "A" dimension for your specific water heater by referencing figure 4B. Cut a 6 inch opening through the wall in the location as shown. Determine the location of electrical wiring, pipes, or wall studs before cutting.

NOTE: Installations requiring an "A" dimension (vertical height) greater than what is shown as standard in the table will require the use of a vertical extension kit (See "Vertical Install Kit" on Page 11).

Figure 4B  
Optional Installation

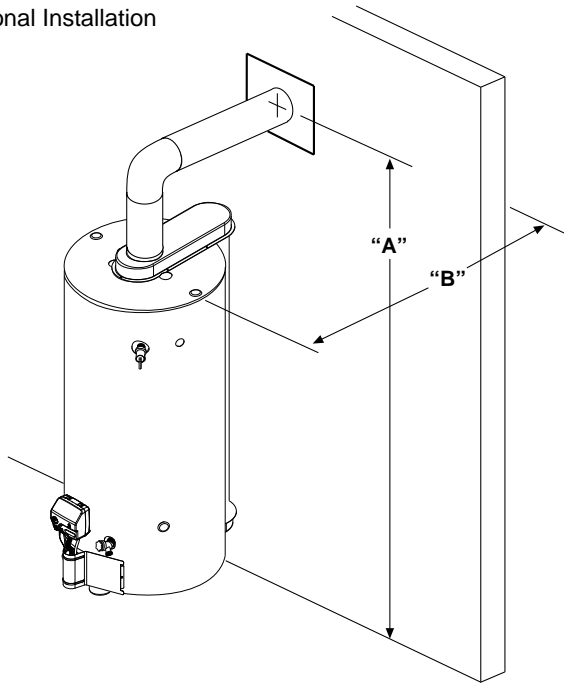

NOTE:

1. Dim. "A" measured from center of cutout to bottom of heater.
2. Dim. "B" measured from center of heater to outside of wall.

4. Extend the 3" telescoping pipe to its maximum length. Place the smaller section onto the 3" elbow at least 1 and 1/2 inches (See Figure 6). Drill two holes 180° apart and secure with the two #8 sheet metal screws provided. Apply silicone sealant to the joint.
5. Attach the larger section of the 5" telescoping pipe to the flange on the outer wall plate (See Figure 6). Drill holes 90° apart with a 1/8" drill bit and fasten with four #8 sheet metal screws (provided). Apply silicone sealant to the seam.
6. Extend the 5" telescoping tube to its maximum length. From outside of the building, insert a 5" tube/outer wall plate assembly through the opening in the exterior wall and onto the 5" elbow (See Figure 6). Seat the base of the outer wall plate onto the exterior wall. Apply silicone sealant between the plate and the exterior wall.

Figure 6:  
Vertical Installation

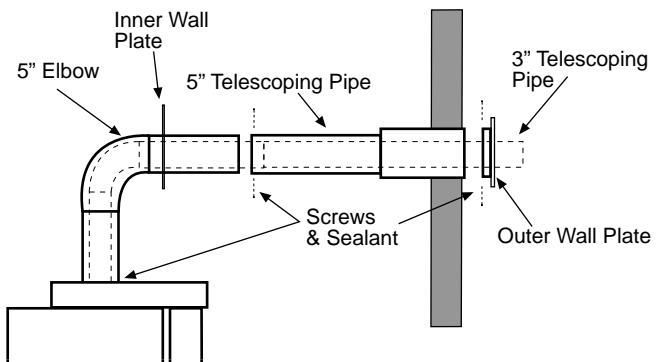
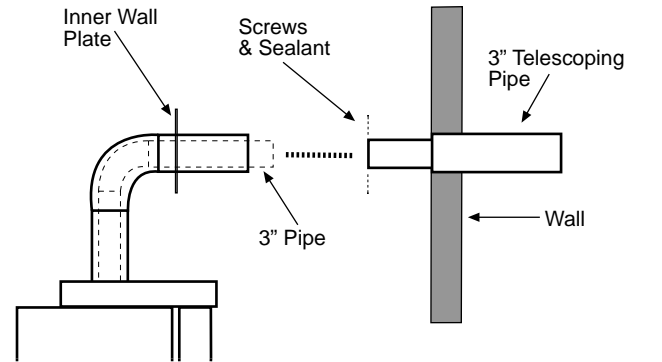

7. Place the 3" tube located in the vent cap into the end of the 3" telescoping tube (See Figure 7). Drill two holes 180° apart with a 1/8" drill bit and secure with two #8 sheet metal screws. Apply sealant to the joint. Seat the cap against outer wall plate with the word "HOT" in an upright position.
8. Secure the vent cap/outer wall plate assembly to the exterior wall with the four 1 and 1/2" screws provided (See Figure 7). Varying wall structures may require a different type of screw anchor. To prevent rain from entering the water heater vent pipe, the 5" tube should be sloped downward towards the wall 1/4" per foot.

Figure 5  
Vertical Installation

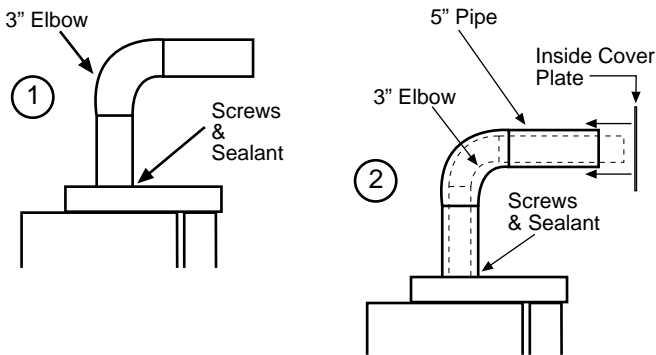
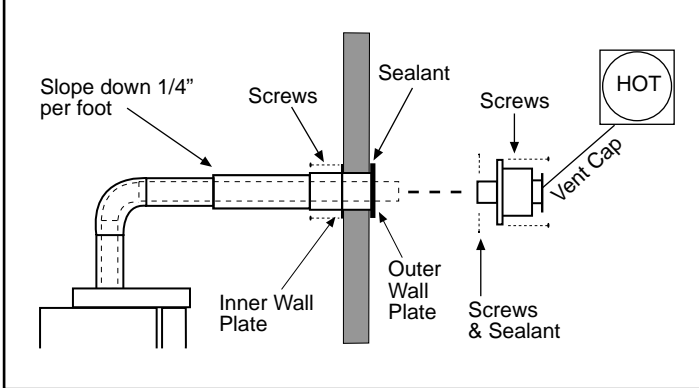

Figure 7  
Vertical Installation



9. Position and fasten the inner wall plate to the inside wall using an appropriate fastener for the specific wall construction. Apply silicone sealant between the inner wall plate and the inside wall.
10. Make certain the 5" telescoping pipe has been fully engaged onto the 5 inch elbow. Drill two 1/8" holes 180° apart at the junction of the two joints. Secure with four #8 sheet metal screws and apply silicone sealant to the seams. Make sure all the 5" pipe joints are sealed including the joint to the collar on the water heater's air supply box (See Figure 8).

### Optional Vertical Extension Kit

Installations requiring dimension "A" to be greater than 62.75" (40 Gallon) or 71.00" (50 Gallon) will require the use of the optional vertical extension kit. The maximum height of the "A" dimension cannot exceed 98 inches. If the "A" dimension for your application is less than 98 inches, you will have to cut the 3 and 5 inch pipes in the vertical extension kit to the correct length. For example, if your applicable "A" distance is 80 inches, then 98 inches - 80 inches = 18 inches. Therefore, you will need to cut 18 inches from both the 3 and 5 inch vertical extension pipes. **DO NOT CUT THE CRIMPED END OF THE 5 INCH PIPE.**

After cutting both the pipes to the proper size, place the 3" vertical extension pipe over the flue pipe reducer on the upper air box and press it firmly downward until seated. Using a level, make sure the extension tube is pointing straight up. Drill 4 holes 90° apart with a 1/8" drill bit and fasten with four #8 sheet metal screws (provided). Apply silicone sealant to the seam.

Place the uncrimped end of the 5 inch extension pipe over the 3 inch extension pipe and seat it onto the collar on the air box. Making sure the 3 inch extension pipe is centered in the 5 inch pipe, drill four holes 90° apart with the 1/8" drill bit and fasten with four #8 sheet metal screws (provided). Apply silicone sealant to the seam. Place the flared end of the 3 inch elbow over the 3 inch extension pipe and press it firmly downward until seated. Drill four holes 90° apart with the 1/8" drill and fasten with four #8 sheet metal screws (provided). Apply silicone sealant to the seam.

Install the 5 inch elbow over the 3 inch elbow and seat it down onto the crimped end of the 5 inch extension pipe. Temporarily place the 5 inch telescoping pipe onto the 5 inch elbow and adjust it to give a 1/4 inch per foot downward slope to the outside wall. Secure the 5 inch elbow to the extension pipe by drilling four holes 90° apart with the 1/8" drill and inserting four #8 sheet metal screws. Apply silicone sealant to the joint. Place the inner wall cover plate over the 5 inch elbow. This plate will be positioned later. Proceed to step 4.

### Through The Roof Venting\*

1. Center the heater directly under the roof opening. This vent system must be installed vertically only.
2. All the pipes needed to assemble the vent are included in the kit. Do not add to the length of the vent system. The total height is limited to 15 feet on a 50-gallon heater (See Figure 8). The 40-gallon heater is 8 and 1/4" shorter. The total 15-foot height must stick through the roof a minimum of 2 feet. If the height needed is less than 15 feet, determine the height needed and subtract that from 15 feet. That amount needs to be cut off one of the 3" pipes and 5" pipes. Cut the non-flared end of the 3" pipe and the uncrimped end of the 5" pipe.
3. Assemble the kit from the top down starting with the termination. Attach a 3" pipe using 4 #8 sheet metal screws 90° apart and seal the joint with sealant. Then attach the 5" section in the same manor. Drill 1/8" pilot holes for the screws. Continue until the full length is assembled. Put the telescoping 5" section on last.
4. Place the heater in position, feed the vent assembly down through the roof with the flashing in place, and allow it to rest with the 3" pipe attached to the 3" vent terminal on the heater. Use screws and sealant to secure that joint. Extend the 5" telescoping section to connect to the 5" termination on the heater. Secure that joint with screws. Seal that joint and the sliding joint with silicone to make an airtight assembly.
5. Secure the flashing and vent assembly to the roof.

(\*Through the Roof Venting Kit available from manufacturer)

Figure 8

Through the Roof Venting

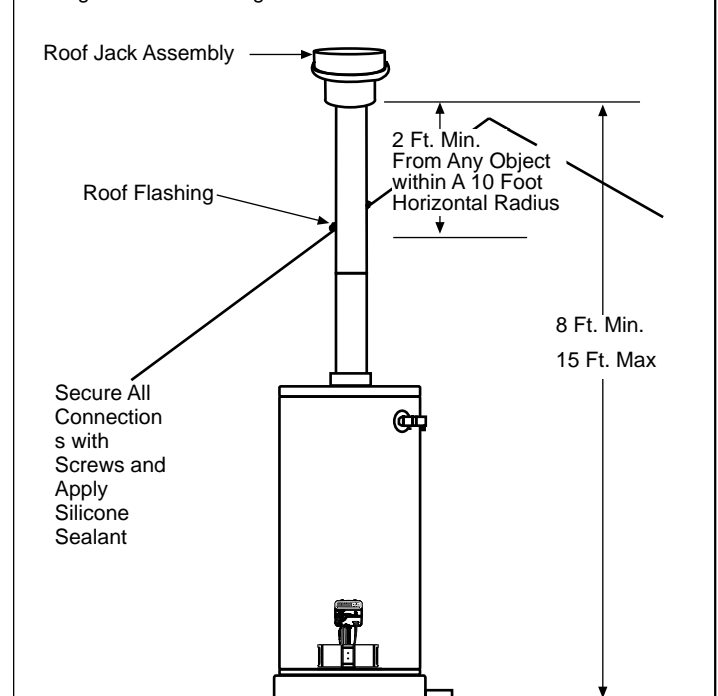

# Vent Cap Termination

## ⚠️ WARNING

### Carbon Monoxide Hazard

Follow all instructions to locate and install vent cap terminal.

Instructions can be found in this manual, in state and local codes (or the authority having jurisdiction), or in the absence of such, the National Fuel Gas Code, ANSI Z223.1, NFPA 54, Current Edition.

Failure to properly locate and install the vent terminal can result in death, carbon monoxide poisoning.

The termination of the vent cap must be in accordance with the local code or the authority having jurisdiction, or in the absence of such, the National Fuel Gas Code, ANSI Z223.1, NFPA 54, Current Edition.

Do not terminate the vent cap in areas containing acid forming chemicals. Inlet air must not contain any corrosive elements. Any water heater failure due to corrosive elements in the atmosphere is excluded from warranty coverage.

See Figures 7 and 8 for correct Vent Cap Termination Locations.

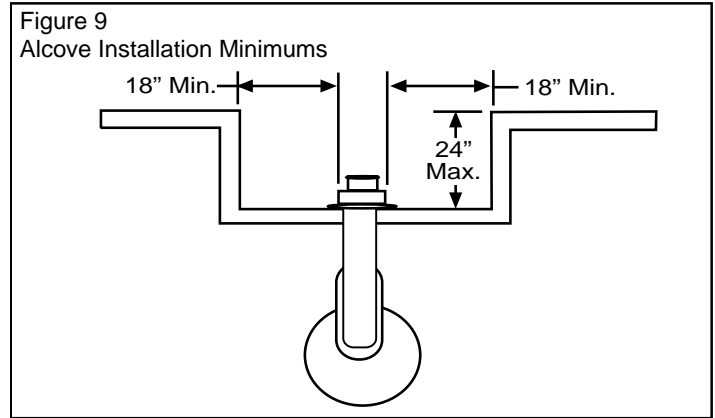
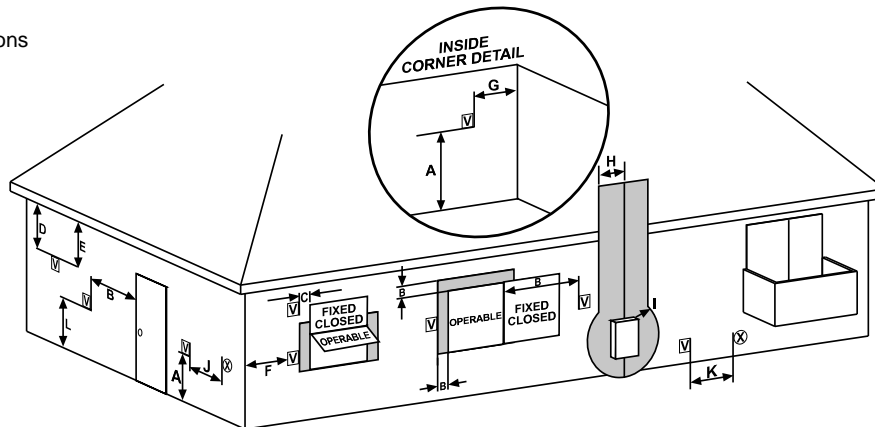

Figure 10  
Vent Cap Termination Locations



### U.S. Installation

⊗ Air Supply Inlet √ Vent Terminal □ Area Where Terminal Is Not Permitted

- |  |  |
|--|--|
| <p>A. 12 in (30 cm) min. clearance above grade, veranda, porch, deck, balcony, or maximum anticipated snow level.</p> <p>B. 9 in (23 cm) min. clearance on top and side of window or door that may be opened. Do not install below a window or door that may be opened.</p> <p>C. Clearance to permanently closed window.**</p> <p>D. 12 in (30 cm) min vertical clearance to ventilated soffit.</p> <p>E. 12 in (30 cm) min. clearance to unventilated soffit.</p> <p>F. Clearance to outside corner **</p> | <p>G. 12 in (30 cm) min. clearance to inside corner formed by two exterior walls.</p> <p>H. 4 ft (122 cm) min. clearance to each side of center line extending above meter/regulator assembly.</p> <p>I. 4 ft (122 cm) min. clearance to service regulator vent outlet.</p> <p>J. 12 in (30 cm) min. clearance to nonmechanical air supply inlet to building or the combustion air inlet to any other appliance.</p> <p>K. 3 ft (91 cm) above if within 10 ft (3 m) horizontally of mechanical air supply inlet.</p> |
|--|--|

\*\*Clearance in accordance with local installation codes and the requirements of the gas supplier

The Vent terminal is HOT when the water heater is in operation. Do not touch the vent terminal or place any object where contact with the vent terminal may occur. A protective louvered wall or fence is recommended when the hot vent cap is low enough to be touched accidentally (see Figure 5). A Vent guard kit (Kit # 6907245) may be ordered by contacting the manufacturer of this water heater at 1-800-999-9515.

- The exhaust outlet must not terminate under a patio, deck, or any covered area.
- Do not terminate the exhaust outlet near walkways or into alleys or other publicly accessible areas.
- Do not locate the vent terminal too close to shrubs or bushes.
- Caulk all cracks, seams, and joints within 6 feet horizontally above and below the vent.
- Do not terminate the vent within 12 inches of any other direct vented appliance vent

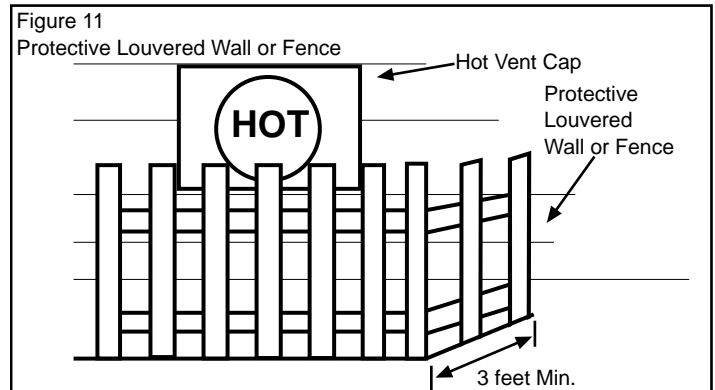

# Water System Piping

## Piping Installation

Piping, fittings, and valves should be installed according to the installation drawing (Figure 12). If the indoor installation area is subject to freezing temperatures, the water piping must be protected by insulation.

The water supply pressure should not exceed 80 psi. If this occurs, a pressure reducing valve with a bypass should be installed in the cold water inlet line. This should be placed on the supply to the entire house in order to maintain equal hot and cold water pressures.

**IMPORTANT:** Heat cannot be applied to the water fittings on the heater as they may contain nonmetallic parts. If solder connections are used, solder the pipe to the adapter before attaching the adapter to the hot and cold water fittings.

**IMPORTANT:** Always use a good grade of joint compound and be certain that all fittings are drawn up tight.

1. Install the water piping and fittings as shown in Figure 13. Connect the cold water supply (3/4" NPT) to the fitting marked "C". Connect the hot water supply (3/4" NPT) to the fitting marked "H".

**IMPORTANT:** Some models may contain energy saving heat traps to prevent the circulation of hot water within the pipes. Do not remove the inserts within the heat traps.

2. The installation of unions in both the hot and cold water supply lines is recommended for ease of removing the water heater for service or replacement.
3. The manufacturer of this water heater recommends installing a mixing valve or an anti-scald device in the domestic hot water line as shown in Figure 13. These valves reduce the point-of-use temperature of the water by mixing cold and hot water and are readily available for use.
4. If installing the water heater in a closed water system, install an expansion tank in the cold water line as specified under "Closed System/Thermal Expansion" section.
5. Install a shut-off valve in the cold water inlet line. It should be located close to the water heater and be easily accessible. Know the location of this valve and how to shut off the water to the heater.
6. A temperature and pressure relief valve must be installed in the opening marked "Temperature and Pressure (T & P) Relief Valve" on the water heater. A discharge line must be added to the opening of the T&P Relief Valve. Follow the instructions under "Temperature and Pressure Relief Valve" section.

7. After piping has been properly connected to the water heater, remove the aerator at the nearest hot water faucet. Open the hot water faucet and allow the tank to completely fill with water. To purge the lines of any excess air, keep the hot water faucet open for 3 minutes after a constant flow of water is obtained. Close the faucet and check all connections for leaks.

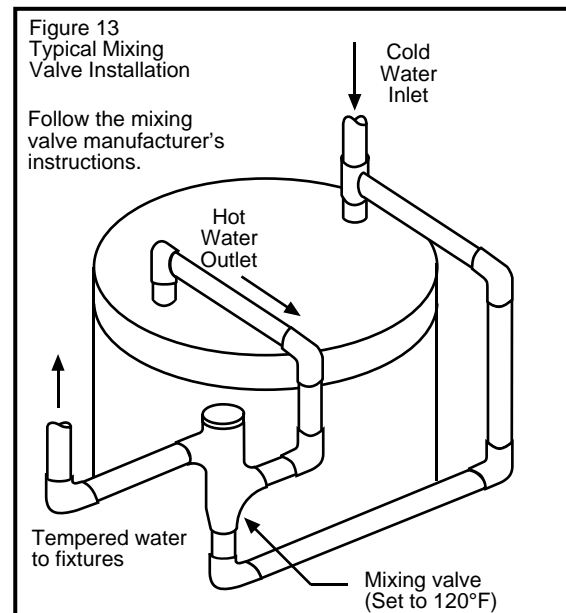
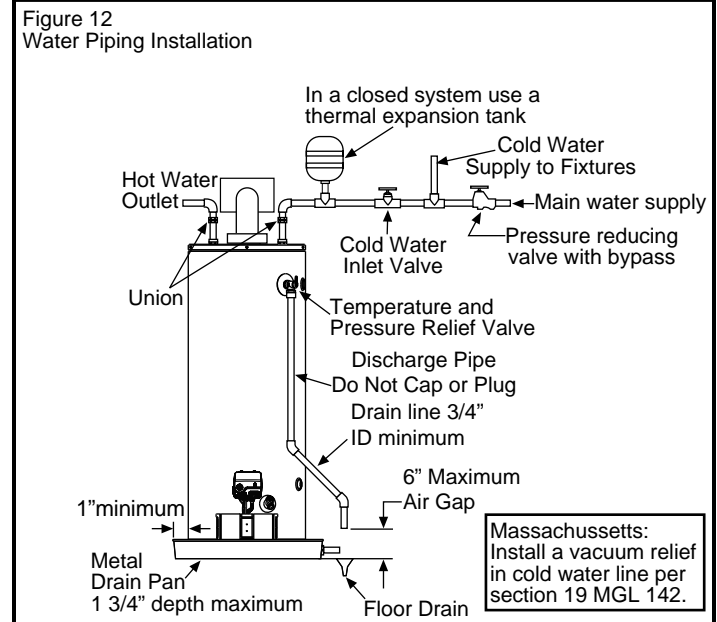

Please note the following:

- The system should be installed only with piping that is suitable for potable (drinkable) water such as copper, CPVC, or polybutylene. This water heater must not be installed using iron piping or PVC water piping.
- Use only pumps, valves, or fittings that are compatible with potable water.
- Use only full flow ball or gate valves. The use of valves that may cause excessive restriction to water flow is not recommended.
- Use only 95/5 tin-antimony or other equivalent solder. Any lead based solder must not be used.
- Piping that has been treated with chromates, boiler seal, or other chemicals must not be used.
- Chemicals that may contaminate the potable water supply must not be added to the piping system.

## Closed System/Thermal Expansion

### **WARNING**



#### **Explosion Hazard**

**If the temperature and pressure relief valve is dripping or leaking, have a qualified person replace it.**

**Examples of a qualified person include: licensed plumbers, authorized gas company personnel, and authorized service personnel.**

**Do not plug valve.**

**Do not remove valve.**

**Failure to follow these instructions can result in death, or explosion.**

As water is heated, it expands (thermal expansion). In a closed system, the volume of water will grow. As the volume of water grows, there will be a corresponding increase in water pressure due to thermal expansion. Thermal expansion can cause premature tank failure (leakage). This type of failure is not covered under the limited warranty. Thermal expansion can also cause intermittent temperature-pressure relief valve operation: water discharged from the valve due to excessive pressure build up. The temperature-pressure relief valve is not intended for the constant relief of thermal expansion. This condition is not covered under the limited warranty.

A properly-sized thermal expansion tank should be installed on all closed systems to control the effects of thermal expansion. Contact a plumbing service agency or your retail supplier regarding the installation of a thermal expansion tank.

# Temperature and Pressure Relief Valve

## ⚠ WARNING



### Explosion Hazard

If the temperature and pressure relief valve is dripping or leaking, have a qualified person replace it.

Examples of a qualified person include: licensed plumbers, authorized gas company personnel, and authorized service personnel.

Do not plug valve.

Do not remove valve.

Failure to follow these instructions can result in death, or explosion.

Figure 14A  
Temperature and Pressure Relief Valve Installation

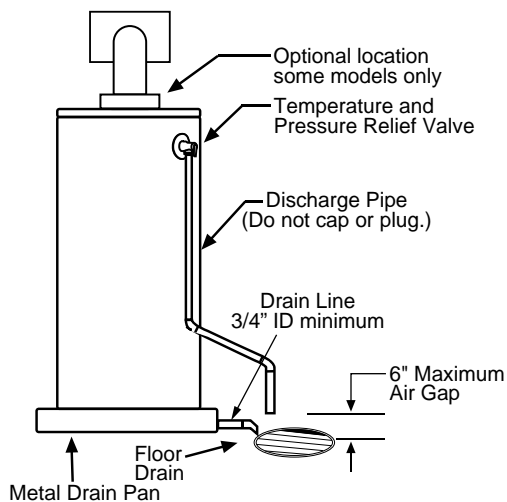

For protection against excessive pressures and temperatures, a temperature and pressure relief valve must be installed in the opening marked "T & P RELIEF VALVE" (see Figure 14A). This valve must be design certified by a nationally recognized testing laboratory that maintains periodic inspection of the production of listed equipment or materials as meeting the requirements for Relief Valves and Automatic Shut-off Devices for Hot Water Supply Systems, ANSI Z21.22. The function of the temperature and pressure relief valve is to discharge water in large quantities in the event of excessive temperature or pressure developing in the water heater. The valve's relief pressure must not exceed the working pressure of the water heater as stated on the data plate.

**IMPORTANT:** Only a new temperature and pressure relief valve should be used with your water heater. Do not use an old or existing valve as it may be damaged or not adequate for the working pressure of the new water heater. Do not place any valve between the relief valve and the tank.

### The Temperature & Pressure Relief Valve:

- Must not be in contact with any electrical part.
- Must be connected to an adequate discharge line.
- Must not be rated higher than the working pressure shown on the data plate of the water heater.

### The Discharge Line:

- Must not be smaller than the pipe size of the relief valve or have any reducing coupling installed in the discharge line.
- Must not be capped, blocked, plugged or contain any valve between the relief valve and the end of the discharge line.
- Must terminate a maximum of six inches above a floor drain or external to the building. In cold climates, it is recommended that the discharge pipe be terminated at an adequate drain inside the building.
- Must be capable of withstanding 250°F (121°C) without distortion.
- Must be installed to allow complete drainage of both the valve and discharge line.

### T&P Relief Valve and Pipe Insulation (Some Models)

1. Locate the temperature and pressure relief valve on the water heater (also known as a T&P relief valve). See Figure 14B.
  2. Locate the slit running the length of the T&P relief valve insulation.
  3. Spread the slit open and fit the insulation over the T&P relief valve. See Figure 14B. Apply gentle pressure to the insulation to ensure that it is fully seated on the T&P Relief Valve. Once seated, secure the insulation with duct tape.
- IMPORTANT:** The insulation or tape should not block or cover the T&P relief valve drain opening. Also, the insulation or tape should not block or hinder access to the manual relief lever (Figure 14B).
4. Locate the hot water (outlet) & cold water (inlet) pipes to the water heater.
  5. Locate the slit running the length of a section of pipe insulation.
  6. Spread the slit open and slip the insulation over the cold water (inlet) pipe. Apply gentle pressure along the length of the insulation to ensure that it is fully seated around the pipe. Also, ensure that the base of the insulation is flush with the water heater. Once seated, secure the insulation with duct tape.
  7. Repeat steps 5 and 6 for the hot water (outlet) pipe.
  8. Add additional sections of pipe insulation as needed.

Figure 14B  
T&P Relief Valve Insulation

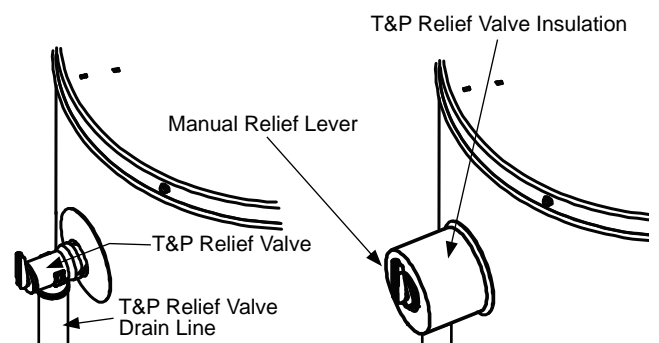

# Special Applications

## Combination Space Heating/Potable Water System

Some water heater models are equipped with inlet/outlet tapplings for use with space heating applications.

**Note:** This water heater is suitable for combination water (potable) heating and space heating and not suitable for space heating applications only. If this water heater is to be used to supply both space heating and potable (drinking water), the instructions listed below must be followed.

- Be sure to follow the manual(s) shipped with the air handler system.
- This water heater is not to be used as a replacement for an existing boiler installation.
- Do not use with piping that has been treated with chromates, boiler seal or other chemicals and do not add any chemicals to the water heater piping.
- If the space heating system requires water temperatures in excess of 120°F, a mixing valve or an anti-scald device should be installed per its manufacturer's instructions in the domestic (potable) hot water supply to limit the risk of scald injury.
- Pumps, valves, piping and fittings must be compatible with potable water.
- A properly installed flow control valve is required to prevent thermosiphoning. Thermosiphoning is the result of a continuous flow of water through the air handler circuit during the off cycle. Weeping (blow off) of the temperature and pressure relief valve (T & P) or higher than normal water temperatures are the first signs of thermosiphoning.
- The domestic hot water line from the water heater should be vertical past any mixing valve or supply line to the air handler to remove air bubbles from the system. Otherwise, these bubbles will be trapped in the air handler heat exchanger coil, reducing the efficiency.
- Do not connect the water heater to any system or components previously used with non-potable water heating appliances when used to supply potable water.

Some jurisdictions may require a backflow preventer in the incoming cold water line. This may cause the temperature and pressure relief valve on the water heater to discharge or weep due to expansion of the heated water. A diaphragm-type expansion tank suitable for potable water will normally eliminate this weeping condition. Please read and follow the manufacturer's instructions for the installation of such tanks.

Also see "Water System Piping" section for additional instructions on the proper installation and operation of this water heater.

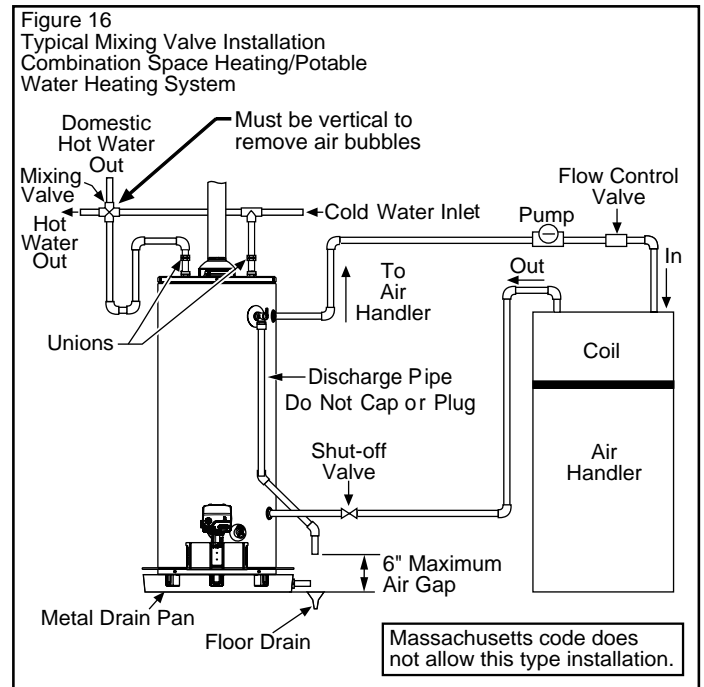

## Solar Installation

If this water heater is used as a solar storage heater or as a backup for the solar system, the water supply temperatures to the water heater tank may be in excess of 115°F. A mixing valve or other temperature limiting valve must be installed in the water supply line to limit the supply temperature to 115°F. The unit must be set to Standard Mode (See Operating the Temperature Control System section).

**NOTE:** Solar water heating systems can often supply water with temperatures exceeding 180°F and may result in water heater malfunction.



# Important Information About This Water Heater

This gas water heater was manufactured to voluntary safety standards to reduce the likelihood of a flammable vapor ignition incident. The new technology used in meeting these standards makes this product more sensitive to installation errors. Please review the following checklist and make any required installation upgrades or changes.

**Questions? Reference the number on the cover of this manual for service information.**

## Installation Checklist

### Water Heater Location

Water heater location is important and can affect system performance. Please check the following:

- Installation area free of corrosive elements and flammable materials.
- Centrally located with the water piping system. Located as close to the gas piping and vent pipe system as possible.
- Located indoors and in a vertical position. Protected from freezing temperatures.
- Proper clearances from combustible surfaces maintained and not installed directly on a carpeted floor.
- Provisions made to protect the area from water damage. Metal drain pan installed and piped to an adequate drain.
- Sufficient room to service the water heater. See "Clearances and Accessibility" section of this manual.
- Water heater not located near an air moving device.

### Combustion Air Supply and Ventilation

- Fresh air supply free of corrosive elements and flammable vapors.

### Vent Pipe System

Check for proper drafting at the water heater draft hood. Refer to the "Checking the Draft" section of this manual for the test procedure. If the procedure shows insufficient draft is present, please check the following.

- Proper location on an outside wall selected for Through the Wall Venting.
- "A" Dimensions determined per water heater to determine whether a Vertical Extension kit is needed.

- Optional Vertical Extension Kit Installed (if necessary).
- Heater centered directly under the roof opening for Through the Roof Venting.
- Through the roof venting has a 15 foot maximum height for the 50 Gallon direct vent water heater and a maximum of 14' 3-1/4" for the 40 Gallon direct vent water heater.
- Vent pipe system installed according to all local and state codes or, in the absence of local and state codes, the "National Fuel Gas Code", ANSI Z223.1(NFPA 54)-current edition.

### Water System Piping

- Temperature and pressure relief valve properly installed with a discharge line run to an open drain and protected from freezing.
- All piping properly installed and free of leaks.
- Heater completely filled with water.
- Closed system pressure build-up devices installed.
- Mixing valve (when applicable) installed per manufacturer's instructions (see "Water Temperature Regulation" section).

### Gas Supply and Piping

- Gas type is the same as that listed on the water heater data plate.
- Gas line equipped with shut-off valve, union, and drip leg.
- Adequate pipe size and approved pipe material.
- An approved noncorrosive leak detection solution used to check all connections and fittings for possible gas leaks. Correct any leak found.

TEFLON<sup>®</sup> is a registered trademark of E.I. Du Pont De Nemours and Company.

# OPERATING YOUR WATER HEATER

## Lighting Instructions

Read and understand these directions thoroughly before attempting to light or re-light the pilot. Make sure the viewport is not missing or damaged. (See Figure 23) Make sure the tank is completely filled with water before lighting the pilot. Check the data plate near the gas control valve/thermostat for the correct gas. Do not use this water heater with any gas other than the one listed on the data plate. If you have any questions or doubts, consult your gas supplier or gas utility company.

## WARNING



### Explosion Hazard

Replace viewport if glass is missing or damaged.

Failure to do so can result in death, explosion or fire.

### FOR YOUR SAFETY READ BEFORE LIGHTING

**WARNING:** If you do not follow these instructions exactly, a fire or explosion may result causing property damage, personal injury or loss of life.

- This appliance has a pilot which is lighted by a piezoelectric igniter. When lighting the pilot, follow these instructions exactly.
- BEFORE LIGHTING** smell all around the appliance area for gas. Be sure to smell next to the floor because some gas is heavier than air and will settle on the floor.  
**WHAT TO DO IF YOU SMELL GAS:**
  - Do not try to light any appliance.
  - Do not touch any electrical switch; do not use any phone in your building.
  - Immediately call your gas supplier from a neighbor's phone. Follow the gas supplier's instructions.
  - If you cannot reach your gas supplier, call the fire department.
- Use only your hand to push in or turn the gas control temperature knob. Never use tools. If the knob will not push in or move by hand, don't try to repair it, call a qualified service technician. Force or attempted repair may result in a fire or explosion.
- Do not use this appliance if any part has been under water. Immediately call a qualified service technician to inspect the appliance. Water heaters subjected to flood conditions or anytime the gas controls, main burner or pilot have been submerged in water require replacement of the entire water heater.
- DO NOT USE THIS APPLIANCE IF THERE HAS BEEN AN IGNITION OF VAPORS.** Immediately call a qualified service technician to inspect the appliance. Water heaters subjected to a flammable vapors ignition will show a discoloration on the air intake grid (bottom of combustion chamber) and require replacement of the entire water heater.

### LIGHTING INSTRUCTIONS

- STOP!** It is imperative that you read all safety warnings before lighting the pilot.
- Turn the gas control/temperature knob counterclockwise to the "OFF" setting.
- Wait ten (10) minutes to clear out any gas. If you then smell gas, **STOP!** Follow "B" in the safety information above on this label. If you do not smell gas, go to the next step.
- Turn the gas control/temperature knob clockwise to "PILOT".
- Press the gas control/temperature knob all the way in and hold it in. The knob should travel in about 1/4 inch (6.35 mm) if it is set to "PILOT" correctly.

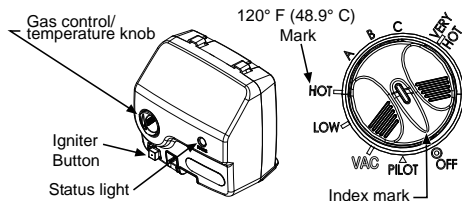

- When the status light starts blinking, release the gas control/temperature knob. Set the gas control/temperature knob to the desired setting.

If the status light does not start blinking within 90 seconds, repeat steps 2 through 5 up to THREE (3) times, waiting 10 minutes between lighting attempts.

The circuitry in this advanced gas valve requires that you wait 10 minutes between lighting attempts.

If the status light turns solid red, release the gas control/temperature knob and repeat steps 2 through 5 (waiting 10 minutes before attempting to relight the pilot).

If the status light does not start blinking after three lighting attempts, turn the gas control/temperature knob to "OFF" and call a qualified service technician or your gas supplier.

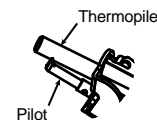
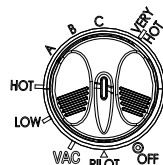

### TO TURN OFF GAS TO APPLIANCE

- Turn the gas control/temperature knob counterclockwise to the "OFF" setting. The status light will stop blinking and stay on for a short time after the water heater is turned off.

## Burner Flames

Inspect the burner flames through the viewport. Flames should be very small with a blue haze and small amounts of yellow or orange at the edges. After several minutes of operation, the burner screen may glow red. If large flames are observed at any time, shut-off unit and call a qualified person.

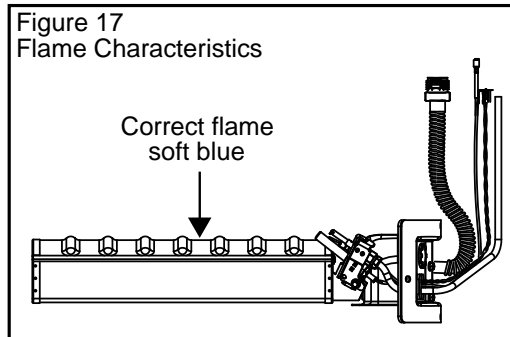

## Water Temperature Stacking

Stacking occurs when a series of short draws of hot water (3 gallons or less) are taken from the water heater tank. This causes increased cycling of the burner and can result in increased water temperatures at the hot water outlet.

This water heater's temperature control has been designed to accurately regulate the water temperature. However, under certain operating conditions, the water temperature may temporarily exceed the dial setting. Consequently, in addition to setting the temperature no higher than 120°F, we recommend the installation of a mixing valve or an anti-scald device in the hot water supply line or at the point of use to further reduce the risk of scald injury. These devices can be obtained from a plumbing service agency or your retail supplier.

## Emergency Shut Down

**IMPORTANT:** Should overheating occur or the gas supply fails to shut off, turn off the water heater's manual gas control valve and call a qualified person.

## Water Temperature Regulation

# ⚠ WARNING

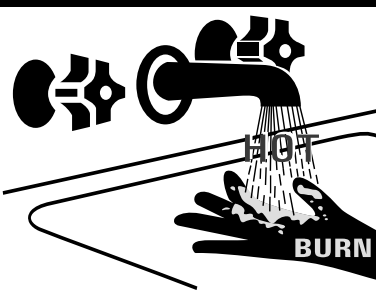

**Water temperature over 125°F can cause severe burns instantly or death from scalds.**

**Children, disabled and elderly are at highest risk of being scalded.**

**Feel water before bathing or showering.**

**Temperature limiting valves are available.**

The thermostat is adjusted to the pilot position when it is shipped from the factory. Water temperature can be regulated by moving the temperature dial to the preferred setting. The preferred starting point is 120°F at the “HOT” setting. Align the knob with the desired water temperature as shown in Figure 18. There is a hot water scald potential if the thermostat is set too high.

**NOTE:** Temperatures shown on the gas control valve/thermostat are approximates. The actual temperature of the heated water may vary.

**IMPORTANT:** Adjusting the thermostat past the 120°F bar on the temperature dial will increase the risk of scald injury. Hot water can produce first degree burns within:

Table 3:

Water Temperature °F	Time for 1st Degree Burn (Less Severe Burns)	Time for Permanent Burns 2nd & 3rd Degree (Most Severe Burns)
110	(normal shower temp.)	
116	(pain threshold)	
116	35 minutes	45 minutes
122	1 minute	5 minutes
131	5 seconds	25 seconds
140	2 seconds	5 seconds
149	1 second	2 seconds
154	instantaneous	1 second

(U.S. Government Memorandum, C.P.S.C., Peter L. Armstrong, Sept. 15, 1978)

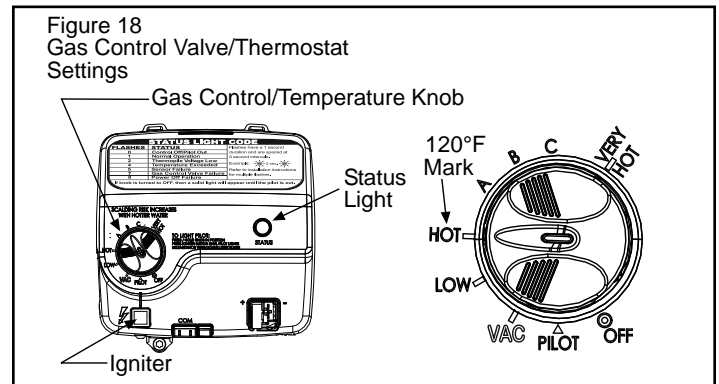

**NOTE:** During low demand periods when hot water is not being used, a lower thermostat setting will reduce energy losses and may satisfy your normal hot water needs. If hot water use is expected to be more than normal, a higher thermostat setting may be required to meet the increased demand. When leaving your home for extended periods (vacations, etc.) turn the temperature dial to the vacation (VAC) setting. This will maintain the water at low temperatures with minimum energy losses and prevent the tank from freezing during cold weather.

# Operating the Temperature Control System

Figure 19: Status Codes

List of status codes are shown at top of gas control valve/thermostat.

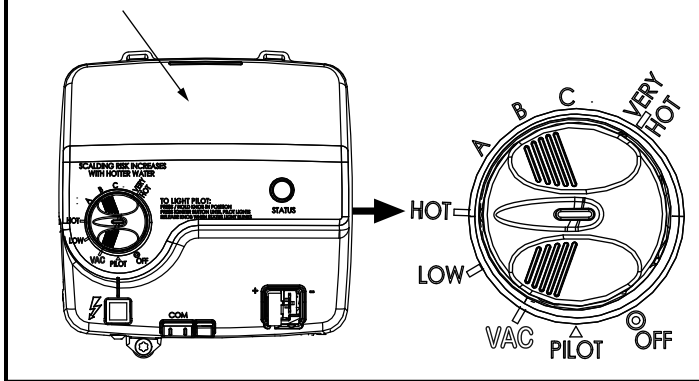

## Status Light Code

### Normal Flashes:

- 0 Flashes Indicates Control Off/Pilot Out.
- 1 Flashes Indicates Normal Operation.
- Continuous Light indicates the gas control valve/thermostat is shutting down.

**Diagnostic Flashes:** If the water heater is not working look for the following diagnostic flashes after lighting the pilot.

- 2 Flashes Indicates Thermopile Voltage Low
- 4 Flashes Indicates Overheat Failure
- 5 Flashes Indicates Sensor Failure
- 7 Flashes Indicates Electronic Control Failure
- 8 Flashes See "Status Light Code Troubleshooting Chart."

## Water Temperature Adjustment

The water temperature can be adjusted from 55°F to 155°F. Turn the Gas Control/Temperature Knob to the desired setting/temperature.

## Operating Modes and Settings

- **Standard Mode** - The controller adjusts the water heater to maintain the temperature set by the user.
- **Vacation Setting** - The controller adjusts the water temperature to approximately 55°F. This setting is recommended when the water heater is not in use for a long period of time. This effectively turns the water heater down to a setting that prevents the water from freezing.

# Operational Conditions

## Condensation

Moisture from the products of combustion condenses on the tank surface and the outside jacket of the water heater and forms drops of water which may fall onto the burner or other hot surfaces. This will produce a “sizzling” or “frying” noise.

**NOTE:** This condensation is normal and should not be confused with a leaking tank. Condensation may increase or decrease at different times of the year.

High efficient energy saver water heaters will produce larger amounts of condensation on initial start-up or when a large amount of hot water is being used. **NOTE:** Do not confuse this with a “tank leak”. Once the water reaches a temperature of 120°F and the tank warms up (usually 1-2 hours), the condensation will stop.

**IMPORTANT:** It is always recommended that a suitable metal drain pan be installed under the water heater to protect the area from water damage resulting from normal condensation production, a leaking tank or piping connections. Refer to “Location Requirements” on page 5. Under no circumstances is the manufacturer to be held responsible for any water damage in connection with this water heater.

## Water Heater Sounds

During the normal operation of the water heater, sounds or noises may be heard. These noises are common and may result from the following:

1. Normal expansion and contraction of metal parts during periods of heat-up and cool-down.
2. Condensation causes sizzling and popping within the burner area and should be considered normal.
3. Sediment buildup in the tank bottom will create varying amounts of noise and may cause premature tank failure. Drain and flush the tank as directed under “Draining and Flushing”.

## Smoke/Odor

The water heater may give off a small amount of smoke and odor during the initial start-up of the unit. This is due to the burning off of oil from metal parts of a new unit and will disappear after a few minutes of operation.

## Safety Shut-off

This water heater is designed to automatically shut-off in the event of the following:

1. The pilot flame is extinguished for any reason.
2. The water temperature exceeds 189°F (87°C).
3. Excessive combustion chamber temperatures.
4. The ignition of flammable vapors.

A thermopile is used to determine if a pilot flame is present, and will shut off the gas supply to the main burner and the pilot if the flame is absent. A temperature limit switch or ECO (Energy Cut Off) sensor located in the gas control valve thermostat is used to shut off the water heater if the water temperature exceeds 189°F (87°C).

The Diagnostic Status Light will flash a code indicating an “Overheat Failure” (4 Flashes). See “Operating the Temperature Control System.” If the ECO has functioned the gas control valve/thermostat should be replaced by a qualified person. Contact your local dealer for service information.

## Anode Rod/Water Odor

Each water heater contains at least one anode rod, which will slowly deplete (due to electrolysis) prolonging the life of the water heater by protecting the glass-lined tank from corrosion. Adverse water quality, hotter water temperatures, high hot water usage, hydronic heating devices, and water softening methods can increase the rate of anode rod depletion. Once the anode rod is depleted, the tank will start to corrode, eventually developing a leak.

Certain water conditions will cause a reaction between the anode rod and the water. The most common complaint associated with the anode rod is a “rotten egg smell” produced from the presence of hydrogen sulfide gas dissolved in the water.

**IMPORTANT:** Do not remove this rod permanently as it will void any warranties. A special anode rod may be available if water odor or discoloration occurs.

**NOTE:** This rod may reduce but not eliminate water odor problems. The water supply system may require special filtration equipment from a water conditioning company to successfully eliminate all water odor problems.

Artificially softened water is exceedingly corrosive because the process substitutes sodium ions for magnesium and calcium ions. The use of a water softener may decrease the life of the water heater tank.

The anode rod should be removed from the water heater tank every 3 years for inspection.

**NOTE:** artificially softened water requires the anode rod to be inspected annually.

The following are typical (but not all) signs of a depleted anode rod:

- The majority of the rods diameter is less than 3/8”.
- Significant sections of the support wire (approx. 1/3 or more of the anode rod's length) are visible.

If the anode rod show signs of either or both it should be replaced. **NOTE:** Whether re-installing or replacing the anode rod, check for any leaks and immediately correct if found.

In replacing the anode:

1. Turn off gas supply to the water heater.
2. Shut off the water supply and open a nearby hot water faucet to depressurize the water tank.
3. Drain approximately 5 gallons of water from tank. (Refer to “Draining and Flushing” for proper procedures). Close drain valve.
4. Remove old anode rod.
5. Use Teflon® tape or approved pipe sealant on threads and install new anode rod.
6. Turn on water supply and open a nearby hot water faucet to purge air from water system.
7. Check for any leaks and immediately correct any if found.
8. Restart the water heater as directed in this manual. See the Repair Parts Illustration for anode rod location.

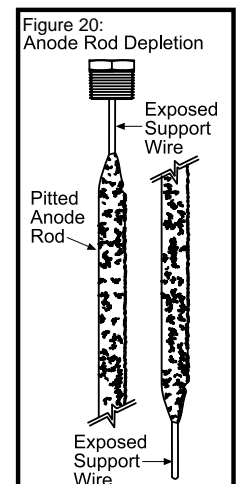

TEFLON® is a registered trademark of E.I. Du Pont De Nemours and Company.

# MAINTENANCE OF YOUR WATER HEATER

## Draining and Flushing

It is recommended that the tank be drained and flushed every 6 months to remove sediment which may build up during operation. The water heater should be drained if being shut down during freezing temperatures. To drain the tank, perform the following steps:

1. Turn off the gas to the water heater at the manual gas shut-off valve.
2. Open a nearby hot water faucet until the water is no longer hot.
3. Close the cold water inlet valve.
4. Connect a hose to the drain valve and terminate it to an adequate drain or external to the building.
5. Open the water heater drain valve and allow all of the water to drain from the tank. Flush the tank with water as needed to remove sediment.
6. Close the drain valve, refill the tank, and restart the heater as directed in this manual.

If the water heater is going to be shut down for an extended period, the drain valve should be left open.

**IMPORTANT:** Condensation may occur when refilling the tank and should not be confused with a tank leak.

## Routine Preventative Maintenance

At least annually, a visual inspection should be made of the venting and air supply system, piping systems, main burner, and pilot burner. Check the water heater for the following:

- Obstructions, damage, or deterioration in the venting system. Make sure the ventilation and combustion air supplies are not obstructed.
- Build up of soot and carbon on the main burner and pilot burner. Check for a soft blue flame.
- Leaking or damaged water and gas piping.
- Presence of flammable or corrosive materials in the installation area.
- Presence of combustible materials near the water heater.
- After servicing this water heater, check to make sure it is working properly. (See Operating Your Water Heater section of this manual.)

**IMPORTANT:** If you lack the necessary skills required to properly perform this visual inspection, you should not proceed, but get help from a qualified person.

## Temperature and Pressure Relief Valve

### ⚠ WARNING



#### Explosion Hazard

**If the temperature and pressure relief valve is dripping or leaking, have a qualified person replace it.**

**Examples of a qualified person include: licensed plumbers, authorized gas company personnel, and authorized service personnel.**

**Do not plug valve.**

**Do not remove valve.**

**Failure to follow these instructions can result in death, or explosion.**

Manually operate the temperature and pressure relief valve at least once a year to make sure it is working properly. To prevent water damage, the valve must be properly connected to a discharge line which terminates

at an adequate drain. Standing clear of the outlet (discharged water may be hot), slowly lift and release the lever handle on the temperature and pressure relief valve to allow the valve to operate freely and return to its closed position. If the valve fails to completely reset and continues to release water, immediately shut off the manual gas control valve and the cold water inlet valve and call a qualified person.

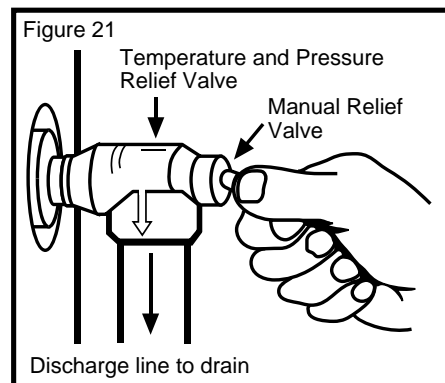

# Replacement Parts

Replacement parts may be ordered through your plumber or the local distributor. Parts will be shipped at prevailing prices and billed accordingly. When ordering replacement parts, always have the following information ready:

1. model, serial, and product number
2. type of gas
3. item number
4. parts description

See pages 30-31 for a list of available repair parts.

## Removing the Burner Door Assembly

1. Turn off the gas to the water heater at the manual shut-off valve (Figure 3).
2. Turn the gas control/temperature knob to the "OFF" position (Figure 18).
3. Remove the outer door.
4. Remove the four screws (1/4" nut driver) securing the burner door assembly to the combustion chamber (Figure 23).
5. Disconnect the pilot tube (7/16" wrench), the igniter wire from the igniter lead wire, and manifold tube (3/4" wrench) at the gas control valve/thermostat. Also disconnect the red (+) and white (-) thermopile wires from the gas control valve/thermostat. See Figures 22 & 23.
6. Grasp the manifold tube and push down slightly, carefully remove the burner door assembly from the burner compartment.

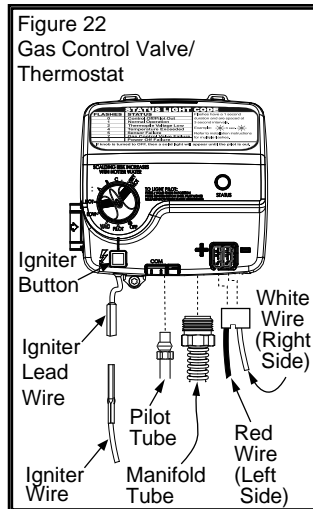

## Natural Gas Burner (Ultra Low Nox)

Check the burner to see if it is dirty or clogged. The burner may be cleaned with soft paint brush (Figure 24). Do not use a wire brush or any tool that may damage the burner screen. Important: Do not use the burner if the burner screen is damaged. NOTE: Damage may be rips or holes in the burner screen. Discoloration is normal.

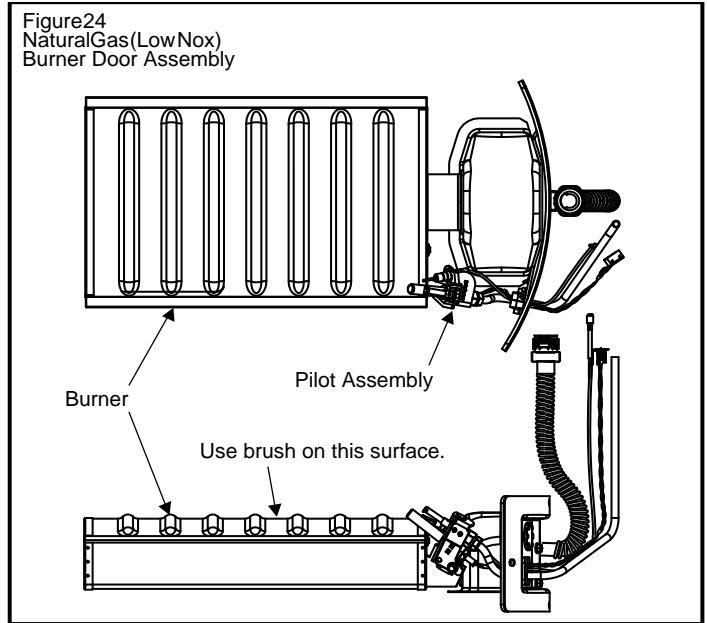

**NOTE:** Be sure not to damage internal parts.

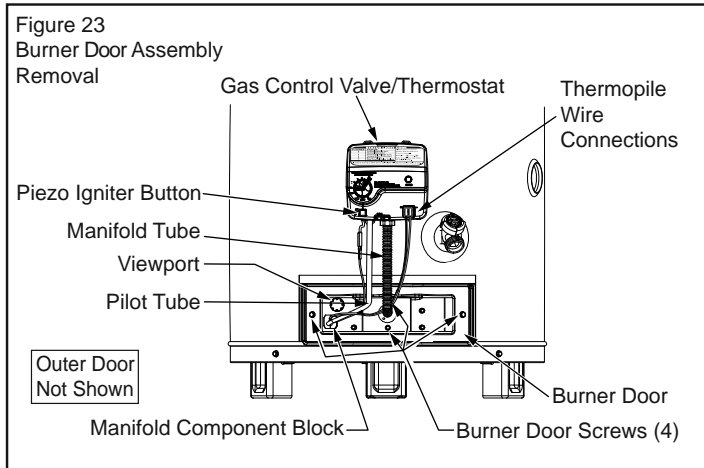



## Replacing the Pilot/Thermopile Assembly

1. Remove the burner door assembly as directed previously.
2. Lift the retainer clip straight up from the back of the manifold component block (using a flat-blade screwdriver), then remove the manifold component block from the burner door assembly (Figure 25).

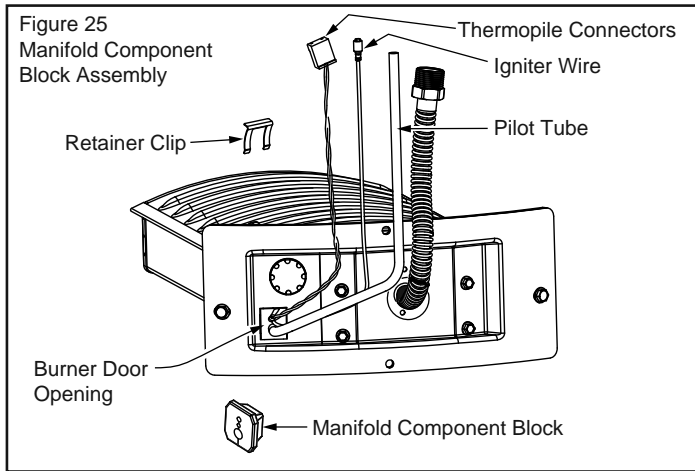

3. Locate and remove the phillips screw attaching the pilot to the pilot bracket, then pull the pilot/thermopile assembly (including the igniter wire) out of the burner door assembly.
4. Using a 7/16" wrench, loosen the nut securing the pilot tube to the pilot assembly (right-hand threads).
5. Pull the pilot tube from the pilot assembly (Figure 26).  
**IMPORTANT:** Be careful not to bend or alter the position of the pilot assembly components.
6. Using the old pilot tube as a guide, bend the new pilot tube to match the old one. Make only the bends closest to the pilot before going to the next step.

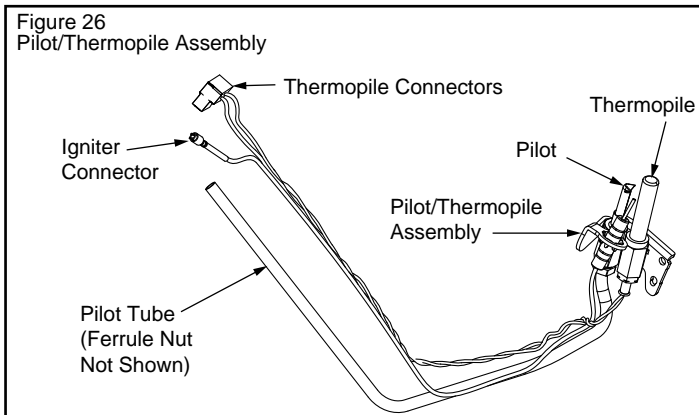

7. Reconnect the pilot tube and tighten the nut securing it to the pilot assembly. To prevent any bending of the pilot bracket, use pliers to hold the pilot assembly bracket while tightening the pilot nut.  
**IMPORTANT:** Keep the pilot orifice in the pilot when making the connection. DO NOT operate the water heater without the pilot orifice installed.
8. Push the new pilot assembly connectors through the opening in the burner door (See Figure 25).
9. Attach the pilot assembly to the Burner Door Assembly.
10. Position the new thermopile wires through the top opening of the manifold component block (Figure 25). Be sure that the igniter wire is positioned through the middle opening of the manifold component block. Position the pilot tube through the bottom opening of the manifold component block.
11. See "Replacing the Burner Door Assembly".

## ⚠ WARNING



### Explosion Hazard

**Tighten all burner door screws securely.**

**Remove any fiberglass between gasket and combustion chamber.**

**Replace viewport if glass is missing or damaged.**

**Replace manifold component block if missing or removed.**

**Replace door gasket if damaged.**

**Failure to follow these instructions can result in death, explosion, or fire.**

## Replacing the Burner Door Assembly

### **⚠ WARNING**



#### Explosion Hazard

Tighten all burner door screws securely.

Remove any fiberglass between gasket and combustion chamber.

Replace viewport if glass is missing or damaged.

Replace manifold component block if missing or removed.

Replace door gasket if damaged.

Failure to follow these instructions can result in death, explosion, or fire.

1. Check the door gasket for damage or imbedded debris prior to installation.
2. Inspect the viewport for damage and replace as required.
3. Insert the burner door assembly into the burner compartment.
4. Inspect the door gasket and make sure there is no fiberglass insulation between the gasket and the combustion chamber.
5. Replace the four screws which secure the burner door assembly to the combustion chamber and tighten securely. There should be no space between the gasket part of the burner door and combustion chamber. **IMPORTANT:** Do not operate the water heater if the door gasket does not create a seal between the burner door and the combustion chamber.
6. Reconnect the manifold tubing (3/4" wrench), pilot tubing (7/16" wrench), temperature sensor wires, and thermopile wires to the gas control valve/thermostat. (See Figure 22 for the correct position of the thermopile wires.) Do not cross-thread or apply any thread sealant to the fittings.
7. Reconnect the igniter wire.
8. Turn the gas supply on and refer to the "Lighting Instructions" on page 18.
9. Check for leaks by brushing on an approved noncorrosive leak detection solution. Bubbles forming indicate a leak. Correct any leak found. **IMPORTANT:** All leaks must be fixed immediately.
10. Replace the outer door.

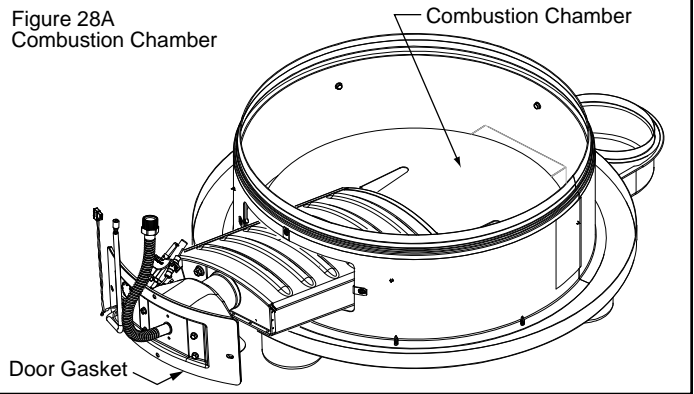
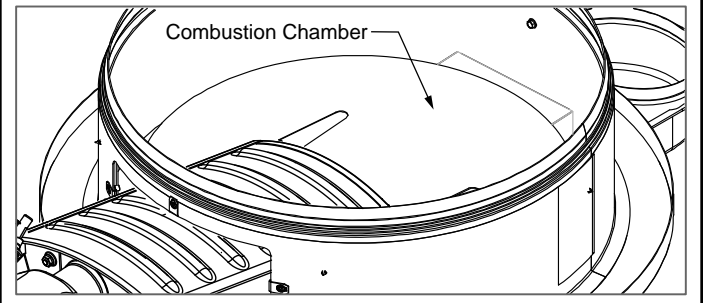
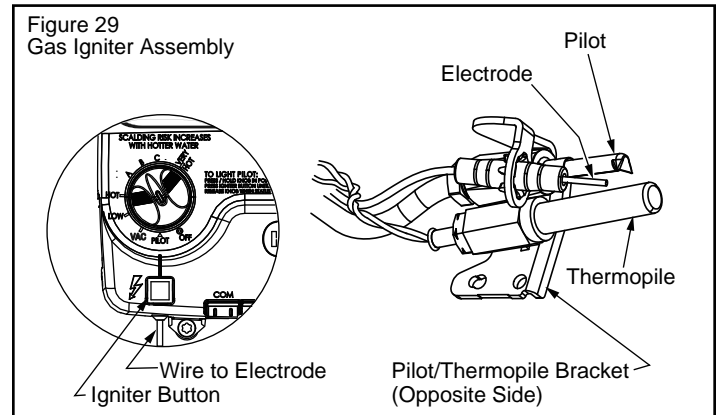

Figure 28B  
Close-up inside view of the combustion chamber



## Piezoelectric Igniter System

The piezoelectric igniter system consists of the igniter button, electrode, and wire. The pilot is ignited by an electric spark generated when the igniter button is pressed. (See Figure 29). Use only factory authorized piezoelectric igniter parts for replacement.



## Testing the Igniter System

Turn off the gas to the water heater at the manual gas shut-off valve. Watch the electrode tip while activating the igniter. A visible spark should jump from the electrode. To avoid shock, do not touch the burner or any metal part on the pilot or pilot assembly. If no spark is visible, check the wire connections and make sure the electrode is not broken. Replace the igniter if defective. Dirt and rust on the pilot or electrode tip can prevent the igniter spark. Wipe clean with a damp cloth and dry completely. Rust can be removed from the electrode tip and metal surfaces by lightly sanding with an emery cloth or fine grit sandpaper.

## Removing and Replacing the Gas Control Valve/Thermostat

**IMPORTANT:** The gas control valve/thermostat is a standard valve with wire leads that connect to the thermopile.

Removing the Gas Control Valve/Thermostat:

1. Turn the gas control/temperature knob to the "OFF" position (Figure 18).
2. Turn off the gas at the manual shut-off valve on the gas supply pipe (Figure 3).
3. Drain the water heater. Refer to the section of "Draining and Flushing" and follow the procedure.
4. Disconnect the igniter wire from the igniter lead wire. Disconnect the temperature sensor wire. Disconnect the red (+) and white (-) thermopile wires. Disconnect the pilot tube (7/16" wrench) and manifold tube (3/4" wrench) at the gas control valve/thermostat (Figure 22).
5. Refer to "Gas Piping" (Figure 3) and disconnect the ground joint union in the gas piping. Disconnect the remaining pipe from the gas control valve/thermostat.
6. To remove the gas control valve/thermostat, thread a 4" section of gas pipe into the inlet and use it to turn the gas control valve/thermostat (counterclockwise.) Do not use pipe wrench or equivalent to grip body. Damage may result, causing leaks. Do not insert any sharp

objects into the inlet or outlet connections. Damage to the gas control valve/thermostat may result.

Gas Control Valve/Thermostat:

To replace the gas control valve/thermostat, reassemble in reverse order. When replacing the gas control valve/thermostat, thread a section of 4" gas pipe into the inlet and use it to turn the gas control valve/thermostat (clockwise.) DO NOT OVER TIGHTEN, damage may result.

- Be sure to use approved Teflon® tape or pipe joint compound on the gas piping connections and fitting on the back of the gas control valve that screws into tank.
- Be sure to remove the pilot ferrule nut from the new gas control valve/thermostat.
- Turn the gas supply on and check for leaks. Test the water heater by brushing on an approved noncorrosive leak detection solution. Bubbles forming indicate a leak. Correct any leak found.
- Be sure tank is completely filled with water before lighting and activating the water heater. Follow the "Lighting Instructions" on page 18.
- If additional information is required, reference the number on the cover of this manual for service information.

## Operational Checklist

1. Manifold gasket properly sealed.
2. Viewport not damaged or cracked.
3. Manifold component block properly installed.
4. No leaks at pilot and manifold connection.
5. Manifold door screws securely tightened.

## TROUBLESHOOTING CHART

PROBLEM	POSSIBLE CAUSE(S)	CORRECTIVE ACTION
BURNER WILL NOT IGNITE	<ol style="list-style-type: none"> <li>1. Pilot not lit</li> <li>2. Thermostat set too low</li> <li>3. No gas</li> <li>4. Dirt in the gas lines</li> <li>5. Pilot line clogged</li> <li>6. Main burner line clogged</li> <li>7. Non-functioning thermopile</li> <li>8. Non-functioning thermostat</li> <li>9. Heater installed in a confined area</li> </ol>	<ol style="list-style-type: none"> <li>1. Light pilot</li> <li>2. Turn temp. dial to desired temperature</li> <li>3. Check with gas utility company</li> <li>4. Notify utility-install trap in gas line</li> <li>5. Clean, locate source and correct</li> <li>6. Clean, locate source and correct</li> <li>7. Replace thermopile</li> <li>8. Replace thermostat</li> <li>9. Provide fresh air ventilation</li> </ol>
SMELLY WATER	<ol style="list-style-type: none"> <li>1. Sulfides in the water</li> </ol>	<ol style="list-style-type: none"> <li>1. Replace the anode with a special anode</li> </ol>
BURNER FLAME YELLOW-LAZY	<ol style="list-style-type: none"> <li>1. Insufficient secondary air</li> <li>2. Low gas pressure</li> <li>3. Flue clogged</li> <li>4. Main burner line clogged</li> <li>5. Obstruction in main burner orifice</li> </ol>	<ol style="list-style-type: none"> <li>1. Provide ventilation to water heater</li> <li>2. Check with gas utility company</li> <li>3. Clean, locate source and correct</li> <li>4. Clean, locate source and correct</li> <li>5. Clean or replace orifice</li> </ol>
PILOT WILL NOT LIGHT OR REMAIN LIT	<ol style="list-style-type: none"> <li>1. Non-functioning igniter</li> <li>2. Thermopile connection loose</li> <li>3. Air in gas line</li> <li>4. Proper Lighting Sequence not followed. Gas Control /Temperature Knob was not held in for sufficient time</li> <li>5. Low gas pressure</li> <li>6. No gas</li> <li>7. Dirt in gas lines</li> <li>8. Cold drafts</li> <li>9. Thermostat ECO switch open</li> <li>10. Pilot line or orifice clogged</li> <li>11. Non-functioning thermopile</li> </ol>	<ol style="list-style-type: none"> <li>1. Replace igniter pilot assembly</li> <li>2. Seat connector firmly in socket</li> <li>3. Bleed the air from the gas line</li> <li>4. Do not attempt to relight if the red light is lit, and the pilot flame is not visible through the view port. Wait until the red light is no longer lit, then follow lighting instructions on the water heater</li> <li>5. Check with gas utility company</li> <li>6. Check with gas utility company</li> <li>7. Notify utility-install dirt trap in gas line</li> <li>8. Locate source and correct</li> <li>9. Replace thermostat</li> <li>10. Clean, locate source and correct</li> <li>11. Replace thermopile</li> </ol>

<b>PROBLEM</b>	<b>POSSIBLE CAUSE(S)</b>	<b>CORRECTIVE ACTION</b>
HIGH OPERATION COSTS	<ol style="list-style-type: none"> <li>1. Thermostat set too high</li> <li>2. Sediment or lime in tank</li> <li>3. Water heater too small for job</li> <li>4. Wrong piping connections</li> <li>5. Leaking faucets</li> <li>6. Gas leaks</li> <li>7. Wasted hot water</li> <li>8. Long runs of exposed piping</li> <li>9. Hot water piping in exposed wall</li> </ol>	<ol style="list-style-type: none"> <li>1. Set temperature dial to lower setting</li> <li>2. Drain/flush-provide water treatment if needed</li> <li>3. Install adequate heater</li> <li>4. Correct piping-dip tube must be in cold inlet</li> <li>5. Repair faucets</li> <li>6. Check with utility-repair at once</li> <li>7. Advise customer</li> <li>8. Insulate piping</li> <li>9. Insulate piping</li> </ol>
INSUFFICIENT HOT WATER	<ol style="list-style-type: none"> <li>1. Thermostat set too low</li> <li>2. Sediment or lime in tank</li> <li>3. Water heater too small</li> <li>4. Wrong piping connections</li> <li>5. Leaking faucets</li> <li>6. Wasted hot water</li> <li>7. Long runs of exposed piping</li> <li>8. Hot water piping in outside wall</li> <li>9. Low gas pressure</li> </ol>	<ol style="list-style-type: none"> <li>1. Turn temperature dial to desired setting</li> <li>2. Drain/flush-provide water treatment if needed</li> <li>3. Install adequate heater</li> <li>4. Correct piping-dip tube must be in cold inlet</li> <li>5. Repair faucets</li> <li>6. Advise customer</li> <li>7. Insulate piping</li> <li>8. Insulate piping</li> <li>9. Check with gas utility company</li> </ol>
SLOW HOT WATER RECOVERY	<ol style="list-style-type: none"> <li>1. Insufficient secondary air</li> <li>2. Flue clogged</li> <li>3. Low gas pressure</li> <li>4. Improper calibration</li> <li>5. Thermostat set too low</li> <li>6. Water heater too small</li> <li>7. Wrong piping connections</li> <li>8. Wasted hot water</li> </ol>	<ol style="list-style-type: none"> <li>1. Provide ventilation to water heater. Check flue way, flue baffle, and burner</li> <li>2. Clean flue, locate source and correct</li> <li>3. Check with gas utility company</li> <li>4. Replace thermostat</li> <li>5. Turn temperature dial to desired setting</li> <li>6. Install adequate heater</li> <li>7. Correct piping-dip tube must be in cold inlet</li> <li>8. Advise customer</li> </ol>
DRIP FROM RELIEF VALVE	<ol style="list-style-type: none"> <li>1. Excessive water pressure</li> <li>2. Heater stacking</li> <li>3. Closed water system</li> </ol>	<ol style="list-style-type: none"> <li>1. Use a pressure reducing valve and relief valve</li> <li>2. Lower the thermostat setting</li> <li>3. See "Closed System/Thermal Expansion"</li> </ol>
THERMOSTAT FAILS TO SHUT-OFF	<ol style="list-style-type: none"> <li>1. Thermostat not functioning properly</li> <li>2. Improper calibration</li> </ol>	<ol style="list-style-type: none"> <li>1. Replace thermostat</li> <li>2. Replace thermostat</li> </ol>
COMBUSTION ODORS	<ol style="list-style-type: none"> <li>1. Insufficient secondary air</li> <li>2. Flue clogged</li> </ol>	<ol style="list-style-type: none"> <li>1. Provide ventilation to water heater. Check flue way, flue baffle, and burner</li> <li>2. Clean, locate source and correct</li> </ol>
SMOKING AND CARBON FORMATION (SOOTING)	<ol style="list-style-type: none"> <li>1. Insufficient secondary air</li> <li>2. Low gas pressure</li> <li>3. Flue clogged</li> <li>4. Thermostat not functioning properly</li> <li>5. Burner flame yellow-lazy</li> </ol>	<ol style="list-style-type: none"> <li>1. Provide ventilation to water heater. Check flue way, flue baffle, burner</li> <li>2. Check with gas utility company</li> <li>3. Clean, locate source and correct</li> <li>4. Replace thermostat</li> <li>5. See "Burner Flame Yellow-Lazy"</li> </ol>
CONDENSATION	<ol style="list-style-type: none"> <li>1. Temperature setting too low</li> </ol>	<ol style="list-style-type: none"> <li>1. Increase the temperature setting</li> </ol>
BURNER FLAME FLOATS AND LIFTS OFF PORTS	<ol style="list-style-type: none"> <li>1. Orifice too large</li> <li>2. High gas pressure</li> <li>3. Flue clogged</li> <li>4. Cold drafts</li> </ol>	<ol style="list-style-type: none"> <li>1. Replace with correct orifice</li> <li>2. Check with gas utility company</li> <li>3. Clean flue and burner-locate source and correct</li> <li>4. Locate source and correct</li> </ol>
BURNER FLAME TOO HIGH	<ol style="list-style-type: none"> <li>1. Orifice too large</li> </ol>	<ol style="list-style-type: none"> <li>1. Replace with correct orifice</li> </ol>
FLAME BURNS AT ORIFICE	<ol style="list-style-type: none"> <li>1. Thermostat not functioning properly</li> <li>2. Low gas pressure</li> </ol>	<ol style="list-style-type: none"> <li>1. Replace thermostat</li> <li>2. Check with gas utility company</li> </ol>
PILOT FLAME TOO SMALL	<ol style="list-style-type: none"> <li>1. Pilot line or orifice clogged</li> <li>2. Low gas pressure</li> </ol>	<ol style="list-style-type: none"> <li>1. Clean, locate source and correct</li> <li>2. Check with gas utility company</li> </ol>

# STATUS LIGHT CODE TROUBLESHOOTING CHART

LED STATUS	PROBLEM	CORRECTIVE ACTION
0 FLASHES (LED NOT LIT)	Pilot light is not lit. Not enough power (millivolts) to keep it lit.	Follow the lighting instructions on the front of the water heater and record any diagnostic codes. See Diagnostic Status Light Code section.
1 FLASH (EVERY 3 SECONDS)	Normal operation.	No corrective action necessary.
2 FLASHES	Insufficient power (millivolts) to the gas control valve/thermostat.	<ol style="list-style-type: none"> <li>1. Check all wiring connections. If problem persists proceed to step 2.</li> <li>2. Replace the thermopile. If you feel uncomfortable with this procedure contact a qualified person.</li> </ol>
4 FLASHES	High water temperature has activated the over heat sensor.	Replace the gas control valve/thermostat. If you feel uncomfortable with this procedure contact a qualified person.
5 FLASHES	Sensor failure	Replace the gas control valve/thermostat. If you feel uncomfortable with this procedure contact a qualified person.
7 FLASHES	Gas Control Valve/Thermostat failure.	Replace the gas control valve/thermostat. If you feel uncomfortable with this procedure contact a qualified person.
8 FLASHES	This condition only appears if the gas control/temperature knob has been turned off and the thermopile continued to produce electric power. This condition can occur if the thermopile does not cool down as quickly as expected when the unit is shut off. This condition can also occur if the gas control/temperature knob has been turned off and the pilot continues to operate because the pilot valve is stuck in the open position.	<p>Make sure that the gas control valve/thermostat knob is set to OFF. Wait one minute. Remove the outer door. Look through the sight glass for a pilot flame. If a pilot flame is observed with the gas control valve/thermostat knob set to the OFF position, the pilot valve is stuck open. Turn the main gas supply OFF. Replace the gas control valve/thermostat. If you feel uncomfortable with this procedure contact a qualified person.</p> <p>If the pilot flame is not observed when the gas control valve/thermostat knob is set to the OFF position, wait 10 minutes for the thermopile to cool, then attempt to relight the pilot by following the lighting instructions on the water heater's label. If this condition returns, replace the gas control valve/thermostat. If you feel uncomfortable with this procedure contact a qualified person.</p>



## Listed Parts Kits and Illustrations

Item 14: Manifold door gasket

Item 18: Viewport

Item 20: Burner Door assembly, which contains the burner, gasket, door, pilot tube, manifold component block with retainer clip, temperature sensor, and pilot assembly. (Natural Gas/Low Nox)

Item 20a: Pilot assembly kit, which contains the pilot, electrode, and thermopile (Natural Gas)

Item 20b: Flexible manifold tube

Item 21: Manifold component block and retainer clip

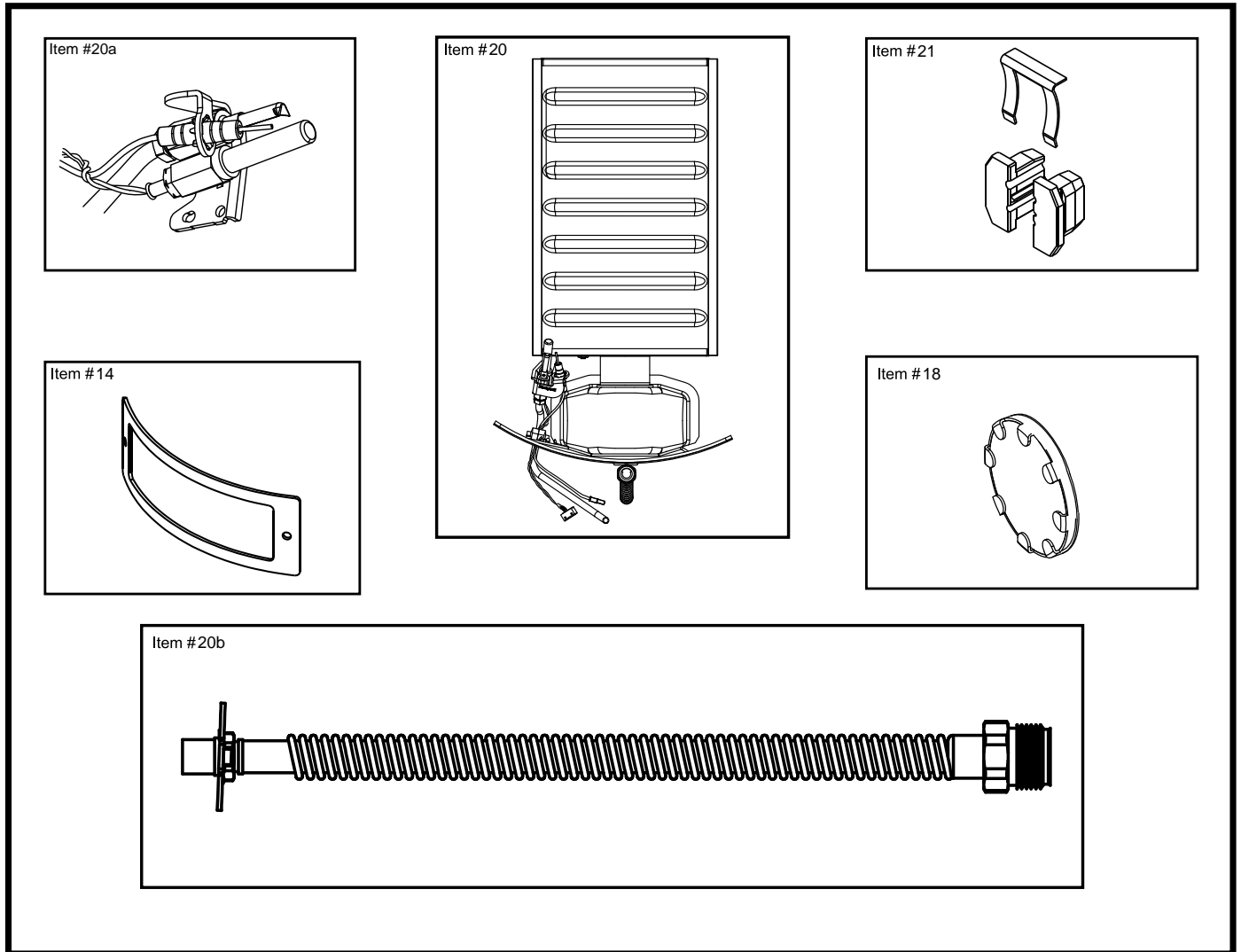

Copyright © 2013 American Water Heater Company.  
All Rights Reserved. Printed in the U.S.