

## PROLINE® XE POWER DIRECT VENT

The ProLine® XE Power Direct Vent water heaters have been engineered to maximize efficiency and deliver a greater Uniform Energy Factor (UEF).

### POWER DIRECT VENT DESIGN

- Combined horizontal and vertical vent runs up to 180 equivalent feet with 4" diameter venting (ABS, PVC, CPVC and polypropylene)
- Two-pipe sealed combustion system uses outside air, eliminating problems caused by insufficient indoor ventilation
- Reduced NOx emissions comply with air quality management district regulations
- Built-in heat traps on the water inlet and outlet reduce the amount of heat lost through piping
- "Environmentally-Friendly" foam insulation reduces the amount of heat loss and contributes to overall energy efficiency

### SELF-CLEANING DIP TUBE

- Helps reduce lime and sediment buildup and maximizes hot water output. Made from long-lasting PEX cross-linked polymer.

### HOT-SURFACE IGNITOR

- More robust and reliable than standing pilot, and reduces energy consumption.

### BLUE DIAMOND® GLASS COATING

- Provides superior corrosion resistance compared to the industry-standard glasslining.

### USER-FRIENDLY

- State-of-the-art electronic gas control provides more precise temperature control
- LED control light displays operation status and diagnostics information

### ENHANCED-FLOW BRASS DRAIN VALVE

- Our residential water heaters have a solid brass, tamper resistant, enhanced-flow, ball type, drain valve.
- Uses a standard female hose fitting that allows for fast and easy draining during maintenance.
- Designed for easy operation, this valve includes an integral screwdriver slot that features a ¼ turn (open/close) radius, which not only permits full straight-through water flow but also a quick and positive shut off.

### CSA CERTIFIED AND ASME RATED T&P RELIEF VALVE

### DESIGN-CERTIFIED BY CSA INTERNATIONAL

- Certified at 150 PSI working pressure.
- Certified to ANSI Z21.10.1-CSA 4.1 or ANSI Z21.10.3-CSA 4.3 standards governing storage tank-type water heaters

### AVAILABLE IN NATURAL GAS AND PROPANE

### 6-YEAR LIMITED TANK AND PARTS WARRANTY





# COMMERCIAL-GRADE RESIDENTIAL GAS WATER HEATERS

Model Number	Series	Nominal Capacity	Rated Storage Volume	First Hour Rating (Gallons)	UEF	BTU Input Per Hour	Recovery @ 90°F Rise Gallon Per Hour	Dimensions in Inches								Approx. Shipping Weight (lb)
								A	B	C	D	E	F	G	H	
PDVG62-40S40-NV	200	40	38	74	0.68	40,000	45	58-1/4	49-5/8	22	29-7/8	11	13-1/4	42-1/2	15-1/4	174
PDVG62-50T45-NV	200	50	48	81	0.72	45,000	50	67-1/2	58-3/4	22	29-7/8	11	13-1/4	51-3/4	15-1/4	192
PDVG62-50T62-NV	200	50	48	118	0.73	62,000**	73	69	60-1/4	22	29-7/8	11	13-1/4	52-3/4	15-1/4	200
PDVG62-75T76-NV	310	75	72	129	0.68	76,000	82	70-5/8	61-1/2	26	33-7/8	11	13-1/4	53	15-1/4	277

All dimensions in inches.  
 For propane models, change "N" to "L" in model number.  
 All models rated for installation at altitudes up to 10,100 ft.  
 Side connections available on PDVG62-40S40 and PDVG62-50T45 models.  
 Side connections standard on PDVG62-50T62 and PDVG62-75T76 models.

Vent Length			
Model Number	Maximum Vent Length Eq. Ft.		
	Ø2"	Ø3"	Ø4"
PDVG62-40S40-NV	50'	125'	180'
PDVG62-50T45-NV	50'	125'	180'
PDVG62-50T62-NV	N/A	50'	125'
PDVG62-75T76-NV	N/A	50'	125'

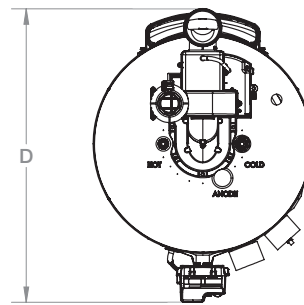

Optional Vent Kits	
Description	Part Number
2" Vent Kit- Coupling, sound suppressor	100158087
3" Vent Kit- Coupling, sound suppressor	100158120
2" Concentric Vent Kit	100112869
3" Concentric Vent Kit	100111100
Hi Ambient Kit	100191116

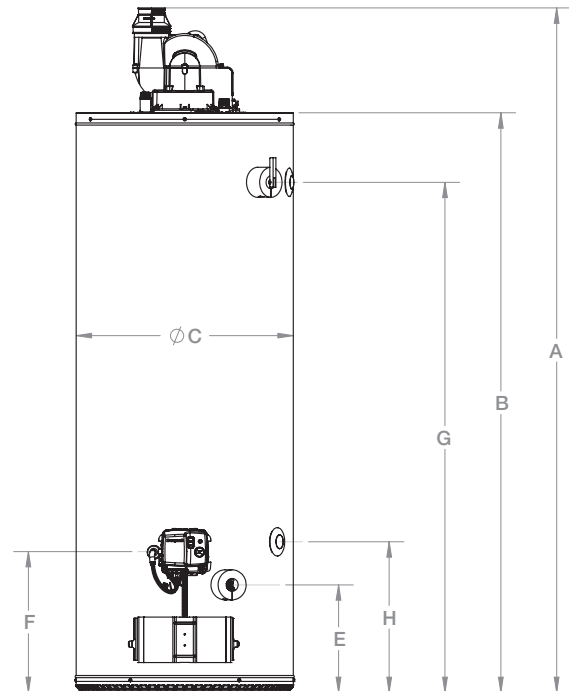

For technical information call (800) 999-9515. American Water Heaters reserves the right to make product changes or improvements without prior notice.