

## PROLINE® MOBILE HOME DIRECT VENT COMMERCIAL-GRADE RESIDENTIAL

### COMPLIES WITH HUD STANDARDS FOR MANUFACTURED HOUSING INSTALLATION

### GAS CONTROL CONVERTIBLE FOR NATURAL AND PROPANE GAS

- For flexibility to meet the varying needs of Manufactured Housing installations.

### SIDE-MOUNTED ¾" COLD WATER INLET

- For ease of installation when cold water supply originates below the structure.
- Top mounted ¾" hot water outlet.

### DIRECT VENT MODELS PACKAGE WITH BOTTOM INTAKE AIR VENT

- To draw all combustion make-up air from outside the structure.

### OPTIONAL DUCTED AIR INLET KIT FOR DIRECT VENT MODELS

- For use when water heater is installed over a basement.
- Provision for horizontal air inlet ducting. See instruction manual for approved venting distance by model.

### GREEN CHOICE® GAS BURNER

- Patented "Eco-Friendly" burner design reduces NOx emissions by up to 33% and complies with low NOx emission requirements of less than 40 ng/J.

### BLUE DIAMOND® GLASS COATING

- Provides superior corrosion resistance compared to industry-standard glass lining.

### ENHANCED-FLOW BRASS DRAIN VALVE

- Our residential water heaters have a solid brass, tamper resistant, enhanced-flow, ball type, drain valve.
- Uses a standard female hose fitting that allows for fast and easy draining during maintenance.
- Designed for easy operation, this valve includes an integral screwdriver slot that features a ¼ turn (open/close) radius, which not only permits full straight-through water flow but also a quick and positive shut off.

### COREGARD™ ANODE ROD

- Our anode rods have a stainless steel core that extends the life of the anode rod allowing superior tank protection far longer than standard anode rods.

### CODE COMPLIANCE

- Meets UBC, CEC and HUD National Codes.
- Meets the thermal efficiency and standby loss requirements of the U. S Department of Energy and current edition of ASHRAE/IES 90.1.
- Complies with the Federal Energy Conservation Standards effective April 16, 2015, in accordance with the Energy Policy and Conservation Act (EPCA), as amended.

### CSA CERTIFIED AND ASME RATED T&P RELIEF VALVE

### MAXIMUM HYDROSTATIC WORKING PRESSURE 150 PSI

### 6-YEAR LIMITED TANK AND 6-YEAR PARTS WARRANTY

- For complete information, consult written warranty or go to [www.americanwaterheater.com](http://www.americanwaterheater.com)





# COMMERCIAL-GRADE RESIDENTIAL GAS WATER HEATERS

Model Number	Gallon Capacity	First Hour Rating Gallon	Energy Factor	Recovery @ 90°F Rise Gallon Per Hour	Btu Input Per Hour Natural Gas	Btu Input Per Hour Propane	Dimensions in Inches							Approx. Shipping Weight (lbs)	
							Insulation	A	B	C	D	E	F		Vent Outlet
MHDV-62-30T30-3NV	30	49	0.63	31	30,000	29,000	2	61	58	18	13	14-1/4	52-1/2	3	129
MHDV-62-40T32-3NV	40	60	0.62	33	32,000	29,000	2	61-3/4	58-3/4	20	13	14-1/4	52-1/4	3	153
MHDV-62-50T40-3NV	50	74	0.60	39	40,000	37,000	2	60	57	22	13	14-1/4	50	3	168

Water connection-3/4" on all models. No option available for top T&P.

All models approved for installation from sea level to 5,400 ft. elevation.

All models ship from the factory for use with natural gas, a complete propane burner is supplied for converting to propane gas. Dimensions and specifications subject to change without notice in accordance with our policy of continuous product improvement.

Kit Number	MIN.	MAX.	Approx. Shipping Weight (lbs)
100285331	-	12"	10
100285333	18"	32"	13
100285412	32"	60"	22
100285414	36"	95"	27

### APPROVED ROOF JACK KITS

Direct Vent Manufactured Housing water heaters must be installed using one of these approved Roof Jack Kits, which must be ordered separately. "Min." and "Max." dimensions indicate kit adjust-ability for varying vent distance, as shown in drawing.

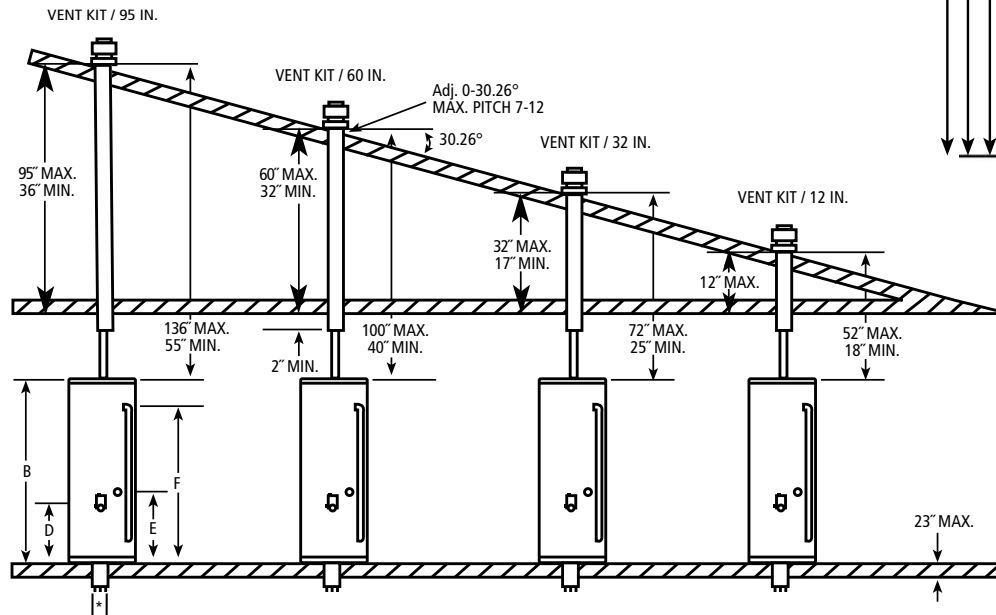

\*Inlet air pipe included 3" diameter for 30 gallon and 40 gallon. 4" diameter for 50 gallon

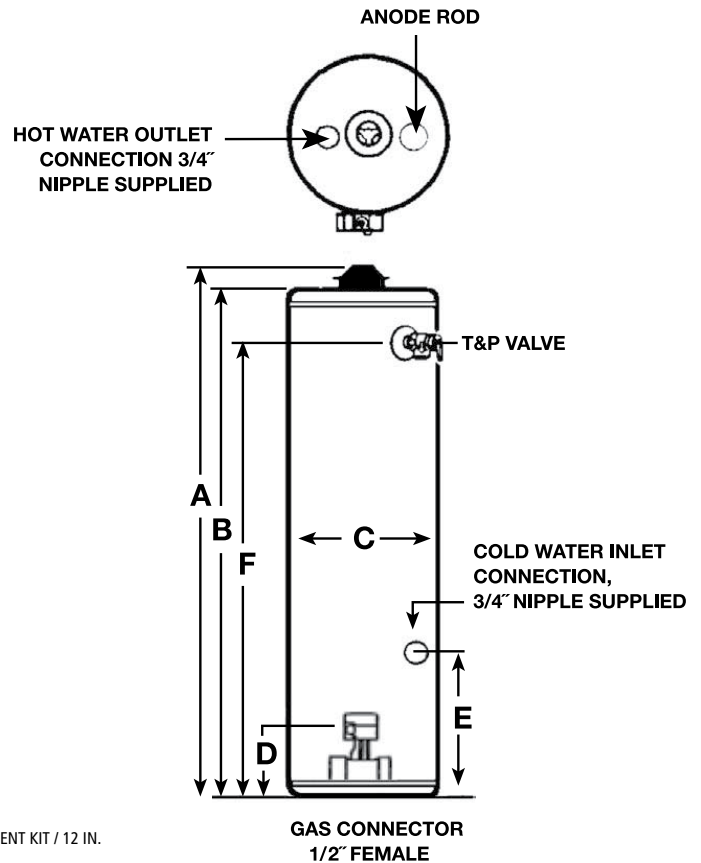

For technical information call (800) 999-9515. American Water Heaters reserves the right to make product changes or improvements without prior notice.