

## TANKLESS FREE STANDING IN-LINE

### LIGHTWEIGHT

- Constructed of anodized aluminum frame
- Utilizes the industry's lightest 199,000 BTU high efficiency condensing tankless heater

### EXPANDABLE

- Multiple design and installation configurations
- Up to 796,000 BTU on a single rack system
- Able to link up to 20 heaters together with multi-link system

### REDUNDANCY

- Multiple combustion systems provide peace of mind
- Easily isolate a unit for maintenance which extends the life of the heaters

### EASY FIELD INSTALLATION

- Reduce installation costs with three simple connections (cold water, hot water, and gas)

### EASILY INTEGRATE STORAGE

- As the world's largest water heater manufacturer, we can easily integrate storage into the design

### WARRANTY

- 1-year limited warranty on rack parts

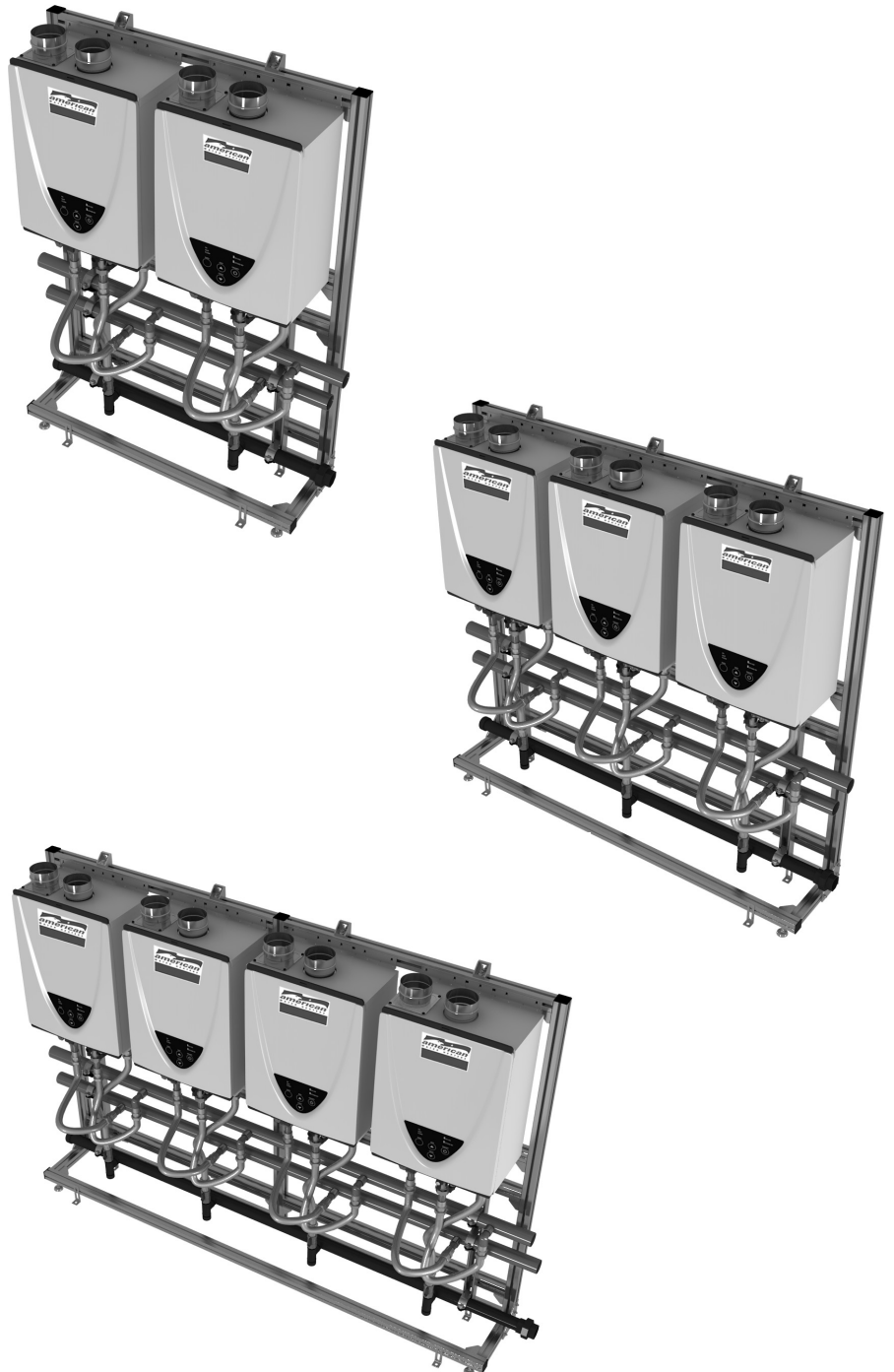



# Commercial Tankless Rack System

Model Number	Number of Heaters	Fuel Type	Gas Consumption Input		Max Flow (GPM)					
			Minimum BTU/h	Maximum BTU/h	@ 50 F Rise	@ 60 F Rise	@ 70 F Rise	@ 80 F Rise	@ 90 F Rise	@ 100 F Rise
<b>Indoor Models</b>										
GT-CRS-2IL-NI	2	Natural	15,000	398,000	15.2	12.6	10.8	9.4	8.4	7.6
GT-CRS-2IL-PI	2	Propane	13,000	398,000	15.2	12.6	10.8	9.4	8.4	7.6
GT-CRS-3IL-NI	3	Natural	15,000	597,000	22.8	18.9	16.2	14.1	12.6	11.4
GT-CRS-3IL-PI	3	Propane	13,000	597,000	22.8	18.9	16.2	14.1	12.6	11.4
GT-CRS-4IL-NI	4	Natural	15,000	796,000	30.4	25.2	21.6	18.8	16.8	15.2
GT-CRS-4IL-PI	4	Propane	13,000	796,000	30.4	25.2	21.6	18.8	16.8	15.2
<b>Outdoor Models</b>										
GT-CRS-2IL-NE	2	Natural	15,000	398,000	15.2	12.6	10.8	9.4	8.4	7.6
GT-CRS-2IL-PE	2	Propane	13,000	398,000	15.2	12.6	10.8	9.4	8.4	7.6
GT-CRS-3IL-NE	3	Natural	15,000	597,000	22.8	18.9	16.2	14.1	12.6	11.4
GT-CRS-3IL-PE	3	Propane	13,000	597,000	22.8	18.9	16.2	14.1	12.6	11.4
GT-CRS-4IL-NE	4	Natural	15,000	796,000	30.4	25.2	21.6	18.8	16.8	15.2
GT-CRS-4IL-PE	4	Propane	13,000	796,000	30.4	25.2	21.6	18.8	16.8	15.2

Model Number	Gas Manifold Connection	Hot/Cold Manifold Connection	Power
<b>Indoor Models</b>			
GT-CRS-2IL-NI	1-1/2" Schedule 40 pipe	2" Copper tube	120 V, 60 Hz, 4.5 A
GT-CRS-2IL-PI	1-1/2" Schedule 40 pipe	2" Copper tube	120 V, 60 Hz, 4.5 A
GT-CRS-3IL-NI	1-1/2" Schedule 40 pipe	2" Copper tube	120 V, 60 Hz, 6.75 A
GT-CRS-3IL-PI	1-1/2" Schedule 40 pipe	2" Copper tube	120 V, 60 Hz, 6.75 A
GT-CRS-4IL-NI	1-1/2" Schedule 40 pipe	2" Copper tube	120 V, 60 Hz, 9 A
GT-CRS-4IL-PI	1-1/2" Schedule 40 pipe	2" Copper tube	120 V, 60 Hz, 9 A
<b>Outdoor Models</b>			
GT-CRS-2IL-NE	1-1/2" Schedule 40 pipe	2" Copper tube	120 V, 60 Hz, 4.5 A
GT-CRS-2IL-PE	1-1/2" Schedule 40 pipe	2" Copper tube	120 V, 60 Hz, 4.5 A
GT-CRS-3IL-NE	1-1/2" Schedule 40 pipe	2" Copper tube	120 V, 60 Hz, 6.75 A
GT-CRS-3IL-PE	1-1/2" Schedule 40 pipe	2" Copper tube	120 V, 60 Hz, 6.75 A
GT-CRS-4IL-NE	1-1/2" Schedule 40 pipe	2" Copper tube	120 V, 60 Hz, 9 A
GT-CRS-4IL-PE	1-1/2" Schedule 40 pipe	2" Copper tube	120 V, 60 Hz, 9 A

Model Number	Dimensions in Inches*			Shipping Dimensions in Inches			Rack + Piping Weight (lbs)	Heater Weight (lbs)	Crate Weight (lbs)	Approx. Shipping Weight (lbs)
	A Height	B Depth	C Width	Height	Depth	Width				
<b>Indoor Models</b>										
GT-CRS-2IL-NI	60-1/2	16	46	67	24	50	107	118	40	265
GT-CRS-2IL-PI	60-1/2	16	46	67	24	50	107	118	40	265
GT-CRS-3IL-NI	60-1/2	16	66	67	24	70	160	177	50	387
GT-CRS-3IL-PI	60-1/2	16	66	67	24	70	160	177	50	387
GT-CRS-4IL-NI	60-1/2	16	86	67	24	90	214	236	80	580
GT-CRS-4IL-PI	60-1/2	16	86	67	24	90	214	236	80	580
<b>Outdoor Models</b>										
GT-CRS-2IL-NE	60-1/2	16	46	67	24	50	107	118	40	265
GT-CRS-2IL-PE	60-1/2	16	46	67	24	50	107	118	40	265
GT-CRS-3IL-NE	60-1/2	16	66	67	24	70	160	177	50	387
GT-CRS-3IL-PE	60-1/2	16	66	67	24	70	160	177	50	387
GT-CRS-4IL-NE	60-1/2	16	86	67	24	90	214	236	80	580
GT-CRS-4IL-PE	60-1/2	16	86	67	24	90	214	236	80	580

\* Line drawings on pages 3, 4, and 5.

Dimensions and specifications subject to change without notice in accordance with our policy of continuous product improvement.

## 2 Unit Free Standing In-Line

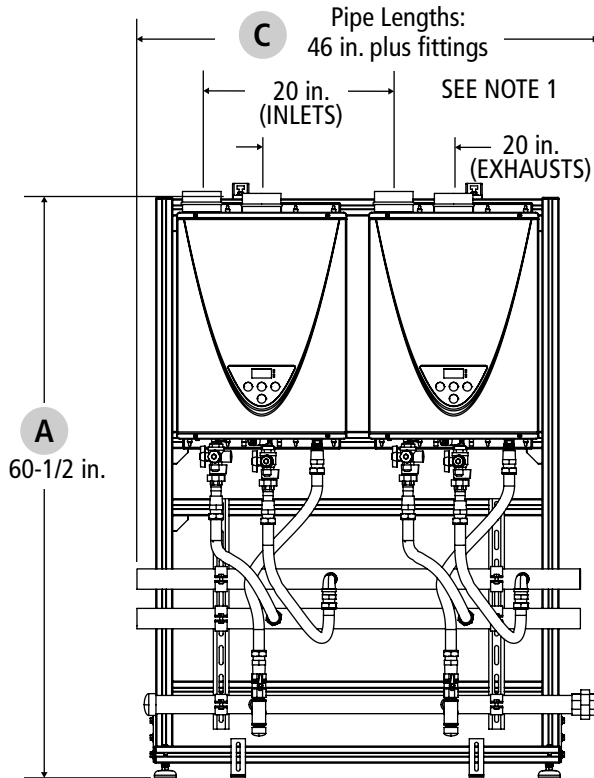

**Front**

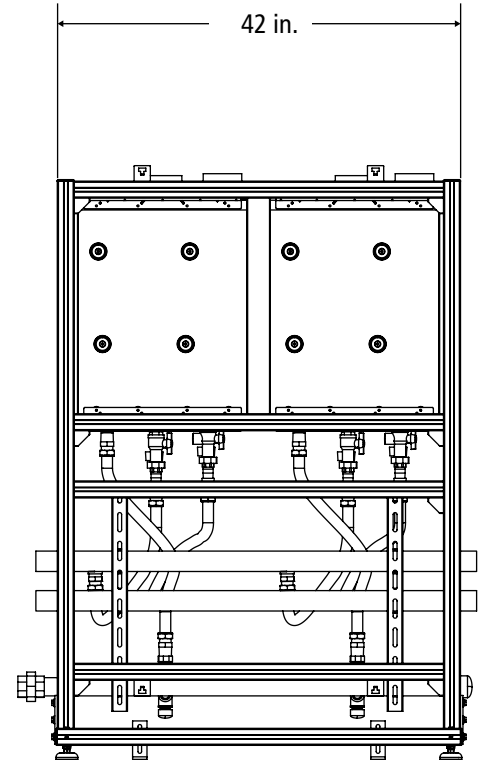

**Back**

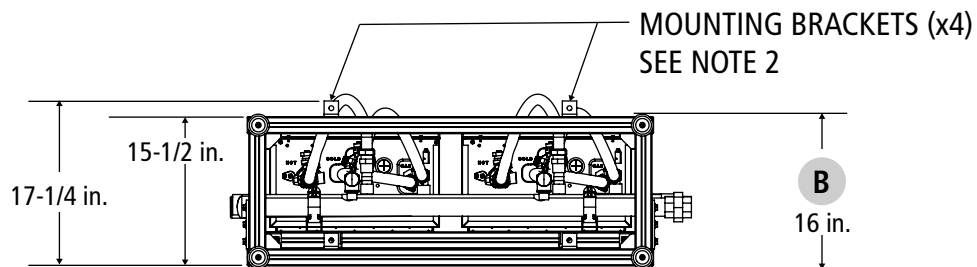

**Bottom**

NOTES:

1. TOP-MOUNTED AIR SUPPLY INLET/EXHAUST VENT ARE USED WITH INDOOR MODELS ONLY.
2. MOUNTING BRACKETS ADJUST HORIZONTALLY ALONG CHANNEL SLOTS.
3. INDOOR AND OUTDOOR RACK SYSTEMS HAVE IDENTICAL DIMENSIONS. EXCEPTION: INDOOR MODELS HAVE TOP-MOUNTED INTAKES AND EXHAUSTS. OUTDOOR MODELS DO NOT.

## 3 Unit Free Standing In-Line

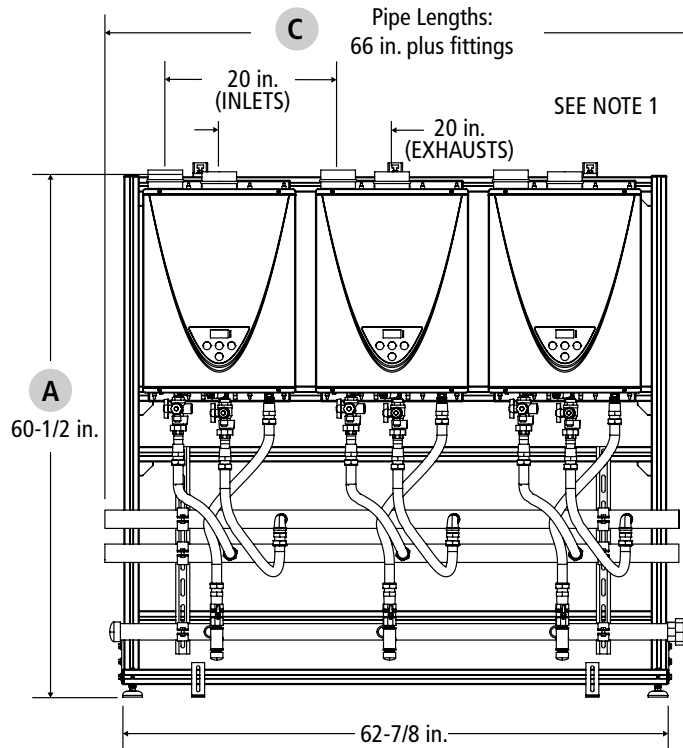

**Front**

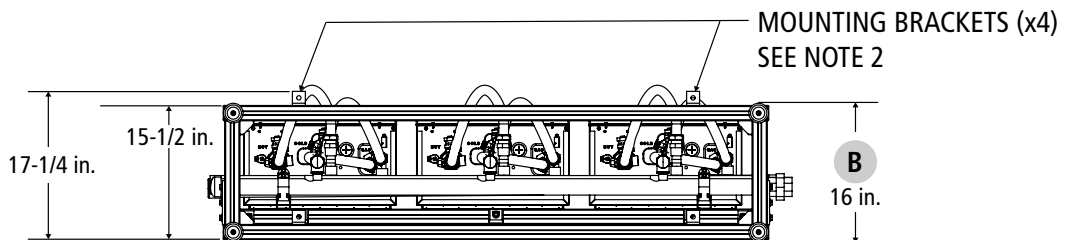

**Bottom**

**NOTES:**

1. TOP-MOUNTED AIR SUPPLY INLET/EXHAUST VENT ARE USED WITH INDOOR MODELS ONLY.
2. MOUNTING BRACKETS ADJUST HORIZONTALLY ALONG CHANNEL SLOTS.
3. INDOOR AND OUTDOOR RACK SYSTEMS HAVE IDENTICAL DIMENSIONS. EXCEPTION: INDOOR MODELS HAVE TOP-MOUNTED INTAKES AND EXHAUSTS. OUTDOOR MODELS DO NOT.

## 4 Unit Free Standing In-Line

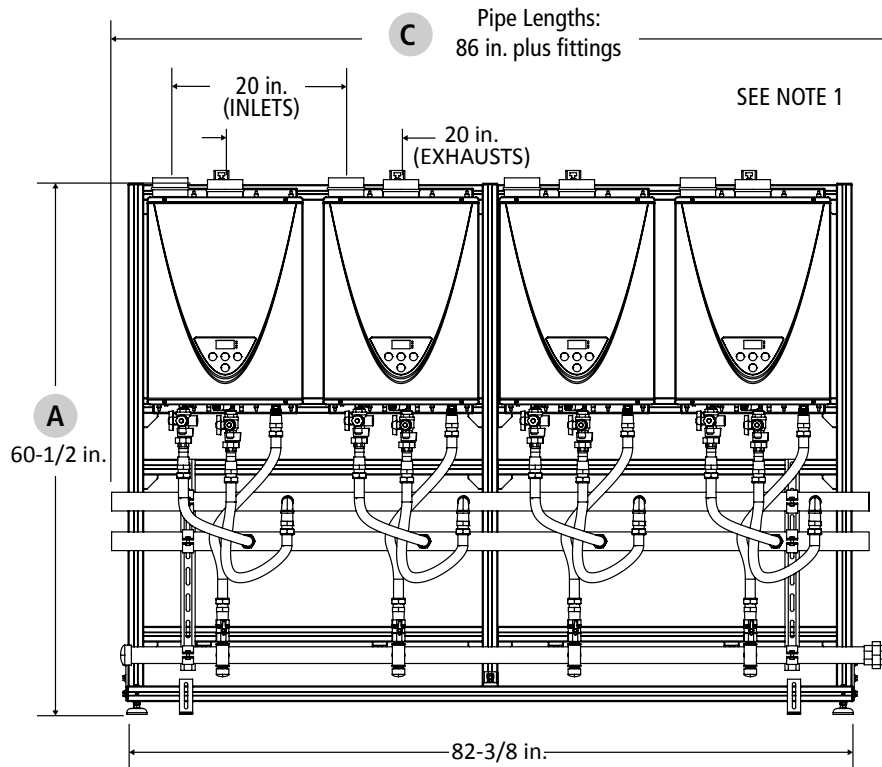

**Front**

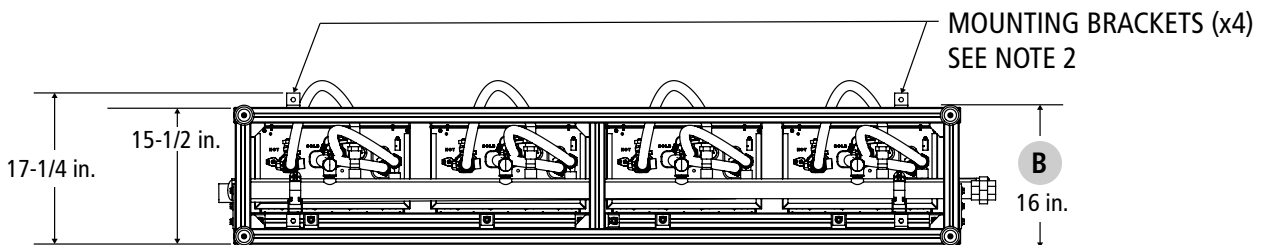

**Bottom**

**NOTES:**

1. TOP-MOUNTED AIR SUPPLY INLET/EXHAUST VENT ARE USED WITH INDOOR MODELS ONLY.
2. MOUNTING BRACKETS ADJUST HORIZONTALLY ALONG CHANNEL SLOTS.
3. INDOOR AND OUTDOOR RACK SYSTEMS HAVE IDENTICAL DIMENSIONS. EXCEPTION: INDOOR MODELS HAVE TOP-MOUNTED INTAKES AND EXHAUSTS. OUTDOOR MODELS DO NOT.



# Commercial Tankless Rack System

## TANKLESS COMMERCIAL RACK SYSTEMS

The Tankless Commercial Rack System model # \_\_\_\_\_ shall be factory assembled pre-plumbed system and includes American GT-540 Condensing Tankless Water Heaters. The Commercial Rack System shall include 2 inch copper water supply lines, 2 foot long  $\frac{3}{4}$  inch flexible stainless steel water lines to the heaters, 1  $\frac{1}{2}$  inch schedule 40 gas supply pipe with 3 foot long  $\frac{3}{4}$  inch CSST flexible gas lines to the heaters, and isolation valves with 150 psi pressure relief valves for each heater. The rack shall be assembled as an in-line floor standing design.

The fully modulating, on-demand, condensing gas fired tankless water heater(s) shall be American Tankless Water Heater model GT-540-\*IH or GT-540-\*EH, having a maximum input rating of 199,000 Btu/h and available in NG or LP. The heater shall have  $\frac{3}{4}$  in. male NPT water and gas connections. The inlet gas supply pressures shall be 4.0 in. WC (min.) up to 10.5 in. WC (max.) for NG and 8.0 in. WC (min.) up to 14 in. WC (max.) for LP. The indoor heater(s) shall incorporate an integrated temperature controller that will provide diagnostic information, fault history, and heater set temperature. The outdoor heater(s) shall be factory supplied with a temperature remote, 9009069005, that can be installed up to 400 ft. from the heater using 20 gauge (minimum) control wire. The temperature remote shall provide diagnostic information, fault history, and additional temperature settings. The heater(s) shall operate using 120 V / 60 Hz power source. The indoor heater(s) will incorporate a factory installed power cord.

The indoor heater(s) shall be vented with 3" or 4" diameter schedule 40 PVC, CPVC, ABS, or Category IV vent pipe with a length not to exceed 70 ft. (equivalent) for 3" vent or 100 ft. (equivalent) for 4" vent, terminating horizontally or vertically. The intake pipe may use material such as PVC, ABS, aluminum, or Category IV pipe and cannot exceed 70 ft. (equivalent) for 3" vent or 100 ft. (equivalent) for 4" vent. The indoor heaters shall be able to be common vented with schedule 40 PVC pipe with a length not exceed 100 ft. (equivalent) using up to 10 inch pipe. Proper sizing is provided in the heater's installation manual. The outdoor heater(s) shall be constructed with an integral exhaust vent on the front of the heater.

The water heater(s) shall use a commercial grade copper, fin tube primary heat exchanger with quick release brass or bronze waterways. The secondary heat exchanger shall be constructed from stainless steel 316L. The heater(s) shall be controlled by an onboard solid-state printed circuit board which uses the following factory installed components: thermistors to monitor water temperature and exhaust temperature; a flow sensor to measure flow rate; a flame sensor to monitor combustion; an air-fuel ratio rod to measure and adjust air inputs in order to maintain optimal combustion efficiency. The heater also consists of inline fusing and surge absorbers for electrical surge protection, an electronic spark igniter, aluminized stainless steel burners, hi-limit temperature switches to monitor water and exhaust temperatures, modulating gas valve, dual freeze protection that will automatically fire the heater (indoor model only) and use heating blocks to protect the heat exchanger, and an overheat cutoff fuse.

The heaters can manifold to Easy-Link up to 4 heaters to provide additional capacity. The Easy-Link controls shall be built onto the onboard solid-state printed circuit board and does not require external controls. The linking control wire shall be supplied with the heater. The heaters can use a Multi-Unit controller, 9008300005, to manifold 5-20 heaters. The Easy-Link and Multi-Unit Controller shall modulate the system for the most efficient performance. The Easy-Link and Multi-Unit Controller shall rotate the priority heater every 12 hours of operation time or 100 starts for balanced duty/cycle operation.

The heater models are design certified by CSA according to ANSI Z21.10.3-2013, approved for sale in the United States, ENERGY STAR® qualified, has a minimum energy factor of 0.95, meets the energy efficiency requirements of the U. S. Department of Energy and ASHRAE 90.1, complies with SCAQMD Rule 1146.2 and other air quality districts with similar requirements for low NOx emissions of 14 ng/J or 20 ppm, and shall be certified to NSF 5 Standards.

For technical information call (800) 999-9515. American Water Heaters reserves the right to make product changes or improvements without prior notice.