

NON-DAMPERED 75 & 100

FULLY AUTOMATIC CONTROLS WITH SAFETY SHUTOFF

- Accurate, dependable control system requires no electric connections. Fixed automatic gas shutoff device for added safety. Maximum temperature setting is up to 181°F.

GREEN CHOICE® GAS BURNER

- Patented eco-friendly burner design reduces NOx emissions by up to 33% and complies with Low-NOx emission requirements of less than 40 ng/J.

ANODIC PROTECTION

PUSH-BUTTON PIEZO IGNITOR

- Makes lighting the pilot fast and easy with one-hand push-button spark ignition.

BLUE DIAMOND® GLASS COATING

- Provides superior corrosion resistance compared to industry standard glass lining.

ENHANCED-FLOW BRASS DRAIN VALVE

- Designed for easy operation, this valve includes an integral screwdriver slot that features a 1/4 turn (open/close) radius, which not only permits full straight-through water flow but also a quick and positive shut off.

STANDARDS AND CERTIFICATIONS

- Meets the thermal efficiency and standby loss requirements of the U. S. Department of Energy and Current Edition ASHRAE/IES 90.1.
- CSA certified and ASME rated T&P relief valve.
- Not recommended for sanitation rinse.

DESIGN-CERTIFIED BY CSA INTERNATIONAL

- Listed according to ANSI Z21.10.3-CSA 4.3 standards governing storage tank-type gas water heaters.

MAXIMUM WORKING PRESSURE

- 150 psi.

MAXIMUM GAS INLET PRESSURE

- 14" W.C.

3-YEAR LIMITED TANK / 1-YEAR LIMITED PARTS WARRANTY

- For complete information, consult written warranty or go to americanwaterheater.com



CG32-75 & CG32-100



Commercial Gas Water Heater

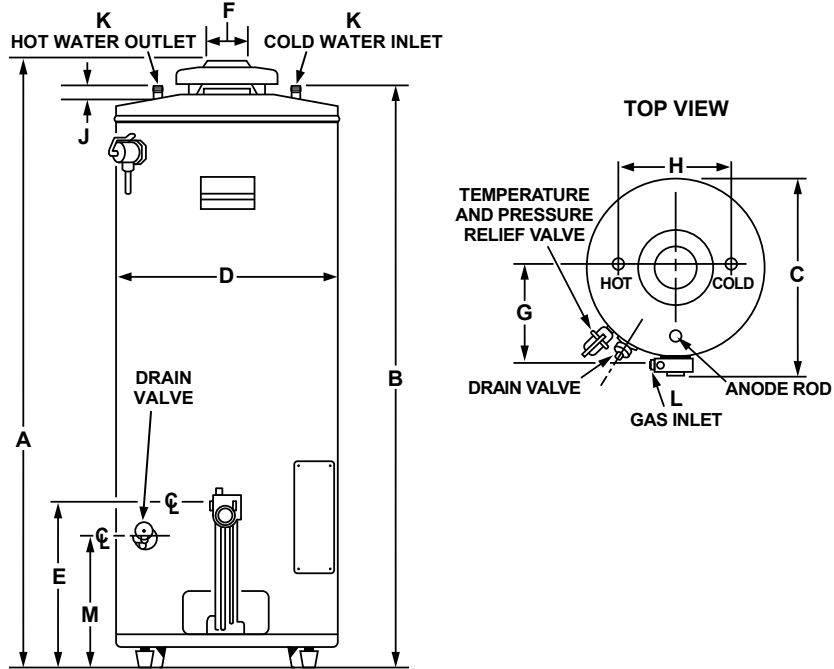

Model Number	Gallon Capacity	Input Rating BTU/HR	Temperature Rise GPH (LPH)											
			30°F (17°C)	40°F (22°C)	50°F (28°C)	60°F (33°C)	70°F (39°C)	80°F (45°C)	90°F (50°C)	100°F (56°C)	110°F (61°C)	120°F (67°C)	130°F (72°C)	140°F (78°C)
CG32-75T75-4NOV	74	75,100	243	182	146	121	104	91	81	73	66	61	56	52
			916	686	550	456	392	343	305	275	249	230	211	196
CG32-100T77-4NOV	98	75,100	243	182	146	121	104	91	81	73	66	61	56	52
			916	686	550	456	392	343	305	275	249	230	211	196

Model Number	Inches/CM	Dimensions in Inches											Approx. Shipping Weight (lbs)	
		A	B	C	D	E	F	G	H	J	K	L		M
CG32-75T75-4NOV	Inches	61-1/8	58-1/2	26-1/2	15-3/16	16	4	14-1/2	29-11/16	54-1/4	1	1/2	11-15/16	275
CG32-100T77-4NOV	Inches	68-5/8	66-1/2	27-3/4	15-3/16	16	4	15-3/4	30-15/16	54-1/4	1	1/2	11-15/16	350

For Propane change the "NO" to "P" in the model number. Exp. CG32-75T75-PV

SPECIFICATION

Water heater(s) shall be Model _____ as manufactured by American Water Heaters or an approved equal. Water heater(s) shall be of glasslined design, and equipped to burn _____ gas. The gas-fired water heater shall be design certified by Underwriters Laboratories Inc. under American National Standard/CSA Standard for Gas Water Heaters ANSI Z21.10.3/CSA 4.3 (current edition) and shall be approved by the Underwriters Laboratories to NSF Standard 5 (with optional leg kit). Heaters must meet all applicable energy codes. Heaters shall have an input rating of ____ BTU/H and a recovery capacity of 73 GPH at a temperature rise of 100°F with a storage capacity of ____ gallons. Heater shall be equipped with a 2-3/4" x 3-3/4" boiler-type handhole cleanout and shall have a working pressure of 150 psi. Heater(s) shall be provided with an automatic gas shutoff device and safety shutoff in the event the pilot flame is extinguished; a gas pressure regulator set for the type of gas supplied; an approved draft diverter, and extruded anode rod rigidly supported for cathodic protection. A CSA Certified and ASME Rated T&P Relief Valve shall be furnished and installed by the manufacturer. The tank shall be foam insulated. The outer jacket shall have a baked enamel finish over a bonderized undercoating. All internal surfaces of the heater exposed to water shall be glasslined with an alkaline borosilicate composition that has been fused-to-steel by firing at a temperature range of 1400° to 1600°F. Heater tank shall have a three year limited warranty against corrosion and tank failure due to sediment build-up as outlined in the written warranty. Operation of the heater in a closed system where thermal expansion has not been compensated for with a properly sized expansion tank will void the warranty. Fully illustrated instruction manual and parts list to be included.

For technical information call (800) 456-9805. American Water Heaters reserves the right to make product changes or improvements without prior notice.