



MCT-199 - TWO HEATERS, CIRCULATION TANK WITH RECIRCULATION AND TMV

LEGEND

	TEMPERATURE & PRESSURE RELIEF VALVE		DRAIN		COLD
	THERMOSTATIC MIXING VALVE		BALL VALVE		HOT
	PRESSURE RELIEF VALVE		TEMPERATURE GAUGE		BUILDING RETURN
	CIRCULATING PUMP		CHECK VALVE		GAS
	TEMPERATURE CONTROL PROBE		WATER FLOW SWITCH		

WARNING: THIS DRAWING SHOWS A SUGGESTED CONFIGURATION AND OTHER DEVICES; CHECK WITH LOCAL CODES AND ORDINANCES FOR ADDITIONAL REQUIREMENTS.

DRAWING SHOWS INDOOR UNITS. OUTDOOR UNITS ARE PIPED IN THE SAME MANNER.

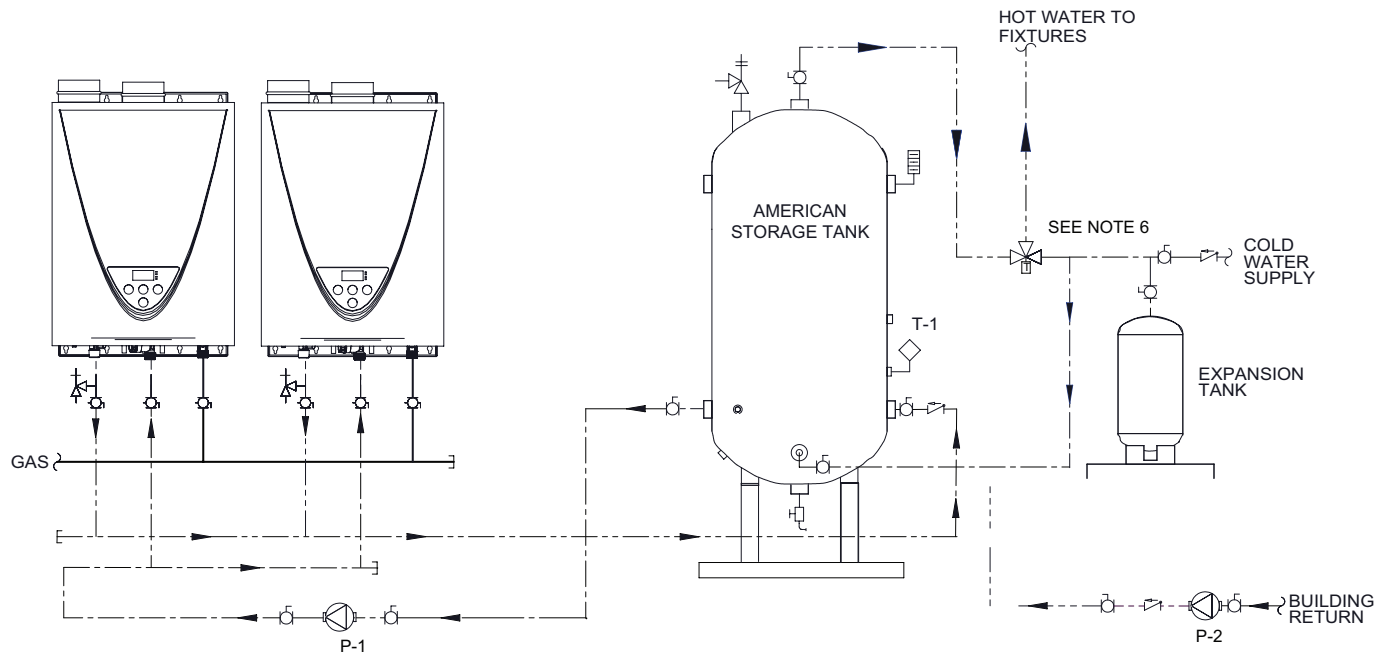

- NOTES:
1. The tank pump, P-1, should provide 5 GPM per heater at 25' TDH for best capacity and efficiency (losses for piping not included). The pump should be controlled by an aquastat, T-1, having an adjustable differential set to a minimum of 15° F. The best efficiency will be achieved by using the largest differential that delivers acceptable storage temperature in the tank.
 2. Building recirculation pump, P-2, to be sized, installed, and controlled by the installer.
 3. Installation of a device to minimize scale deposits, such as the Product Preservers®, water softener, etc. should be considered. Refer to the heater's installation manual for additional information and/or consult with a local water quality expert.
 4. Gas supply line shall be sized per the heater's installation manual and the current edition of ANSI Z223.1/NFPA 54.
 5. Automatic air vent should be installed at the highest point in the system for all installations using a circulation pump.
 6. Install thermostatic mixing valve per manufacturer's instructions.
 7. Drawing shows indoor units. Outdoor units are piped in the same manner.